

Omega-Phone **924**

**Owner's
Manual**
Release 2



SPECIAL NOTICES

TOLL RESTRICTION

The Toll Restriction feature of the Omega-Phone 924 system is one method of preventing fraud (i.e., the making of unauthorized toll calls) by users of the system. The chance of fraud may be reduced but may not be eliminated. Only a complete program which includes but may not be limited to inspection of telephone call billing, use of call detail recorders, and other such devices, systematic monitoring of all telephone call activity, and implementing corrective measures can minimize the possibility of fraud. Iwatsu Voice Networks and/or its Third Party manufacturers/suppliers hereby disclaim any express or implied warranty that its equipment is technically immune from or prevents unlawful and/or unauthorized utilization that may result in unauthorized toll calls. Iwatsu Voice Networks hereby warns Distributor that such is possible.

Use of Call Recorder, Voice Mail Record, and Station Monitor

In certain states it is illegal to intercept, listen to, and/or record telephone calls. In certain states and under certain circumstances it is illegal to intercept for the purposes of listening in and/or recording telephone calls. Because such activity is not illegal in all jurisdictions and may be permitted in training and/or monitoring of personnel, this telephone system can be programmed to permit interception, listening to, and/or recording with or without warning to those on the line. Before utilizing the system for such purposes, you are advised to confirm the laws of the jurisdiction in which you utilize such features(s). Iwatsu Voice Networks and/or its Third Party manufacturers/suppliers disclaim any responsibility for improper or illegal use of the Call Record, Voice Mail Record, and Station Monitor Features and disclaim any obligations to render legal advice concerning this feature.

Electrical Safety Advisory

It is recommended that an AC surge arrestor of the form and capacity suitable for the model of the Omega-Phone 924 purchased be installed in the AC outlet to which the system is connected.

Music-On-Hold

In accordance with U.S. Copyright Law, a license may be required from the American Society of Composers, Authors, and Publishers or other similar organizations, if radio or TV broadcasts are transmitted through the music-on-hold feature of the telecommunications system. Iwatsu Voice Networks and/or its Third Party manufacturers/suppliers hereby disclaim any liability arising out of unlawful and/or unauthorized utilization use of the music-on-hold feature.

All brand names and product names used in this manual are trademarks of their respective companies.

Iwatsu Voice Networks

8001 Jetstar Drive, Irving, TX 75063

(972) 929-0242

Email: info@iwatsu.com, Web: <http://www.iwatsu.com>

© 2009 by Iwatsu America, Inc.

All rights reserved.

Omega-Phone 924 Owner's Manual July 2009

11 10 09

06 05 04 03

All rights are reserved. No part of this manual or accompanying software may be reproduced, in any form or any means, without the permission of Iwatsu Voice Networks.

This manual was written for Omega-Phone 924 systems. In some cases, available feature operations may differ from those listed in this manual, depending on the hardware, software and programmed functions in your Omega-Phone 924. For more information contact your authorized Iwatsu distributor.

Iwatsu Voice Networks has used its best effort to ensure that the information in this manual was accurate at the time of printing. Iwatsu Voice Networks makes no warranty of any kind, expressed or implied, with regard to the contents of this manual. This information is subject to change without notice.

Iwatsu Voice Networks shall not be held responsible for any representation made regarding this information by any individual.

Part Number: 700450

OMEGA-PHONE 924

TABLE OF CONTENTS

SECTION 1 – OMEGA-PHONE 924 GENERAL DESCRIPTION	1
FCC REGISTRATION AND REQUIREMENTS	3
INSTRUCTIONS TO THE USER	3
NOTICES	3
FCC INFORMATION.....	4
OMEGA-PHONE 924 SYSTEM OVERVIEW.....	5
SYSTEM HARDWARE	6
<i>OM-KSU</i>	6
<i>SYSTEM PERIPHERAL CONNECTIONS</i>	7
<i>CONFIGURATION OPTIONS</i>	7
<i>OM-KSU MAIN SYSTEM KSU</i>	8
<i>OM-308 EXPANSION MODULE 3 X 8</i>	9
<i>OM-OPT OPTION MODULE</i>	10
<i>OM-VML VOICE PROCESSING SYSTEM (VOICE MAIL CARD)</i>	11
OMEGA-PHONE 924 STATIONS	12
<i>DIGITAL AND WIRELESS TELEPHONES</i>	12
<i>OM-KTD30 DIGITAL KEY TELEPHONE</i>	12
<i>OM-8WRLS 2.4 GHZ WIRELESS OFFICE SPEAKERPHONE</i>	12
ATTENDANT POSITION	13
DOORPHONE	13
SINGLE LINE TELEPHONES.....	13
SPECIFICATIONS.....	14
SYSTEM CONFIGURATION.....	14
<i>POWER REQUIREMENTS</i>	14
<i>DIMENSIONS</i>	14
<i>MOUNTING</i>	14
<i>OPERATING ENVIRONMENT</i>	14
<i>WIRING</i>	14

<i>MAXIMUM SYSTEM CONFIGURATION</i>	15
<i>CO LINE INTERFACE SPECIFICATIONS</i>	15
<i>SWITCHING TECHNOLOGY</i>	15
<i>EXTENSION INTERFACE SPECIFICATIONS</i>	15
<i>MAXIMUM CABLE LENGTH – DIGITAL EXTENSION WIRING</i>	15
<i>MAXIMUM CABLE LENGTH – SINGLE LINE TELEPHONE WIRING</i>	15
OMEGA-PHONE 924 FEATURES	16
SECTION 2 – DIGITAL TELEPHONE USER GUIDE	19
DIGITAL TELEPHONES	21
OM-KTD30 SPEAKERPHONE WITH NAVIGATION KEYS	21
<i>OM-KTD30 FEATURES</i>	21
OM-8WRLS WIRELESS TELEPHONE	22
OM-KTD30 FEATURES	23
<i>BASIC ELEMENTS OF THE OM-KTD30</i>	23
<i>INTERACTIVE KEYS</i>	24
<i>NAVIGATION KEYS</i>	25
<i>NAVIGATION KEYS</i>	25
GETTING STARTED	26
<i>IDLE TELEPHONE SCREEN</i>	26
<i>WITHOUT THE OPTIONAL OM-VML VOICE MAIL CARD:</i>	26
<i>DISPLAY DEFINITION</i>	26
<i>WITH THE OPTIONAL OM-VML VOICE MAIL CARD:</i>	26
<i>DISPLAY DEFINITION</i>	26
MAKING CALLS	27
<i>INTERCOM CALLS</i>	27
<i>HANDSFREE OPERATION</i>	27
<i>RINGING OPERATION</i>	27
<i>OUTSIDE CALLS</i>	28
<i>SPEAKERPHONE CALLING:</i>	28
ENDING CALLS	29
<i>HANDSET CALLING:</i>	29

<i>SPEAKERPHONE:</i>	29
SWITCHING FROM HANDSET TO SPEAKERPHONE	29
FEATURE OPERATION	30
FEATURE CODES	30
<i>FEATURE CODE TABLE</i>	30
<i>FEATURE CODE TABLE (CONTINUED)</i>	31
<i>FEATURE CODE TABLE (CONTINUED)</i>	32
<i>FEATURE CODE TABLE (CONTINUED)</i>	33
911 SUPPORT	34
ACCESSING SPECIFIC CO LINES	34
ACCOUNT CODE	34
ANSWERING MACHINE EMULATION	35
AUTHORITY CODE (TRAVELING CLASS OF SERVICE)	36
AUTOMATIC HOLD	37
AUTOMATIC SELECTION (CO/INTERCOM)	38
BACKGROUND MUSIC (BGM)	39
BARGE-IN (INTRUSION)	39
BUSY LAMP FIELD (BLF) / DIRECT STATION SELECT (DSS)	39
BUSY RING ALLOW/DENY	41
CALL ATTENDANT (OPERATOR)	41
CALL BACK – EXTENSION	42
CALL FORWARD	42
<i>ONE TOUCH CALL FORWARD:</i>	45
<i>ONE TOUCH FORWARD OPERATION</i>	45
CALL PARK / CALL PARK ANSWER	46
CALL PICK-UP GROUP	47
CALLER IDENTIFICATION - CALL LOG	47
CALL WAITING	48
CONFERENCE	48
DAY AND NIGHT MODES	49
DEFAULT FLEXIBLE KEYS / FEATURE KEY RESET	49

DEFAULT SETTINGS	50
DIRECTED CALL PICKUP	51
DISTINCTIVE RING.....	51
DO NOT DISTURB	51
DO NOT DISTURB - OVERRIDE.....	52
ENHANCED LETTERING SCHEME	52
EXTENSION FEATURE STATUS CHECK.....	53
EXTENSION PASSWORD / PHONE LOCK	54
EXTENSION PICK-UP GROUPS	54
EXTENSION REMINDER	55
FLASH – CENTRAL OFFICE (CO) LINE	55
FORCED INTERCOM TONE RING	56
GROUP CALL PICK-UP	56
HEADSET JACK	57
HOLD, SYSTEM (COMMON) & I – HOLD INDICATION	57
HOLD - REMIND TIME	58
HOLDING CALL ANSWER – SELECT	58
HOT KEY ENABLE / DISABLE	59
HUNT GROUPS	59
<i>LINEAR HUNT</i>	59
<i>ALL RING</i>	59
<i>VOICE MAIL HUNT GROUP</i>	60
INTERCOM CALLING - NON BLOCKING - INTERCOM KEY.....	60
INTERCOM CALL BACK.....	61
LAST NUMBER REDIAL.....	61
LEAST COST ROUTING.....	62
MESSAGE NOTIFICATION AND FORWARDING	62
MESSAGE WAITING	62
MONITOR	63
MUTE.....	64
OFF HOOK VOICE ANNOUNCE	64

ON HOOK DIALING (HOT KEY PAD).....	66
ONE TOUCH TRANSFER.....	66
PAGE.....	66
PAGE (ALLOW / DENY).....	67
PAGE (MEET ME).....	67
PAUSE / PAUSE INSERTION.....	68
PHONE LOCK / UNLOCK.....	68
PROGRAMMABLE FEATURE KEY PROGRAMMING.....	69
PULSE TO TONE (DTMF) CONVERSION.....	73
RECALL.....	73
REMINDER TONES.....	74
RINGING LEVEL / MUTED RINGING.....	74
<i>RINGING LEVEL</i>	74
<i>MUTED RINGING</i>	74
RINGING LINE PRIORITY.....	75
RELAY CONTROL.....	75
SAVE DIALED NUMBER (SDN).....	76
SPEAKERPHONE.....	76
SECURITY CONTROL.....	77
<i>FEATURE 62(X) (X = SENSOR 1 – 4)</i>	77
SPEED DIAL (ABBR) – EXTENSION /SYSTEM.....	78
<i>PROGRAMMING SYSTEM SPEED DIAL</i>	78
<i>EXAMPLES:</i>	79
<i>SPECIAL ENTRY CODES:</i>	80
STATUS MESSAGE.....	80
<i>PRE-PROGRAMMED STATUS MESSAGES:</i>	80
TEXT MESSAGES.....	82
TOUCH TONE ON/OFF.....	83
TRANSFER.....	83
TRANSFER BEEP.....	84
VOICE ANNOUNCE / HANDS-FREE REPLY.....	85

VOICE CALL RECORDER (ONE TOUCH RECORD)	86
VOLUME CONTROL	87
WARNING TONE / CO LINE CALL LIMITER	87
VOICE MAIL SYSTEM (OM-VML CARD)	88
USING YOUR MAILBOX	88
<i>SET UP</i>	88
<i>YOUR MAILBOX WILL GIVE YOU THE FOLLOWING LIST OF OPTIONS:</i>	89
1 - <i>LISTEN TO NEW MESSAGES</i>	89
2 - <i>SEND A NEW MESSAGE</i>	89
3 - <i>CHANGE PASSWORD</i>	89
4 - <i>RECORD GREETINGS</i>	89
5 - <i>RECORD NAME AND SETUP DIAL BY NAME</i>	90
6 - <i>SET PAGER NOTIFICATION</i>	90
7 - <i>REMOTE NOTIFICATION (CELL PHONE)</i>	90
8 - <i>ASSISTANT EXTENSION</i>	90
9 - <i>DIRECT MESSAGE DELIVERY</i>	90
0 - <i>REROUTE CALLER TO ANOTHER EXTENSION</i>	90
* - <i>CLIPBOARD RECORDING (ONE TOUCH RECORD)</i>	91
# - <i>EXIT</i>	91
LISTENING TO MESSAGES	91
1 - <i>LISTEN</i>	91
2 - <i>SAVE</i>	91
3 - <i>DELETE</i>	91
4 - <i>REPLY</i>	92
5 - <i>HEAR THE HEADER INFORMATION</i>	92
6 - <i>COPY THE MESSAGE TO ANOTHER MAILBOX</i>	92
* - <i>SKIP THIS MESSAGE AND SAVE IT AS NEW</i>	92
# - <i>EXIT AND RETURN TO PREVIOUS MENU</i>	92
VOICE MAIL ACCESS FROM AN OUTSIDE LINE	92
<i>LIVE ATTENDANT</i>	92
<i>AUTOMATED ATTENDANT</i>	92

SECTION 3 – ATTENDANT POSITION USER GUIDE	93
ATTENDANT POSITION.....	95
ATTENDANT ADMINISTRATION (ADMIN.).....	95
CALL FORWARD STATUS LAMP CONTROL	96
INCOMING FILTER	96
OPTIONAL SENSOR FUNCTION	97
SERVICE MODE.....	98
SYSTEM SPEED DIAL PROGRAMMING.....	98
VOICE MAIL SHUTDOWN PROCEDURE.....	99
SECTION 4 – SINGLE LINE TELEPHONE USER GUIDE	101
SINGLE LINE TELEPHONES.....	103
<i>SINGLE LINE TELEPHONES (SLT).....</i>	<i>103</i>
FEATURE CODES	104
TELEPHONE FEATURE CODES	104
FEATURE OPERATION	105
ACCESSING SPECIFIC CO LINES	105
ACCOUNT CODE.....	105
AUTHORITY CODE (TRAVELING CLASS OF SERVICE).....	105
CALL ATTENDANT (OPERATOR).....	106
CALL BACK – EXTENSION	106
<i>SLT OPERATION:</i>	<i>106</i>
CALL FORWARD.....	107
<i>ONE TOUCH AND SINGLE LINE TELEPHONE FORWARD OPERATIONS.</i> <i>(THE # KEY IS THE FEATURE KEY ON SLTS).....</i>	<i>108</i>
CALL PICK-UP GROUP.....	109
<i>CALL PICK-UP PRIORITY LIST:</i>	<i>109</i>
DO NOT DISTURB	110
EXTENSION PASSWORD	110
EXTENSION PICK-UP GROUPS.....	111
EXTENSION REMINDER	111

FLASH – CENTRAL OFFICE (CO) LINE	112
FORCED INTERCOM TONE RING	112
GROUP CALL PICK-UP.....	112
HOLD.....	112
LAST NUMBER REDIAL.....	113
LEAST COST ROUTING.....	113
MESSAGE WAITING	113
PAGE	113
PAGE (MEET ME)	114
PHONE LOCK / UNLOCK	114
PULSE TO TONE (DTMF) CONVERSION.....	115
RECALL	115
REMINDER TONES	116
SINGLE LINE TELEPHONE - FLASH	116
SPEED DIAL (ABBR) – EXTENSION /SYSTEM	117
<i>SPECIAL ENTRY CODES:</i>	117
TRANSFER.....	117
WARNING TONE / CO LINE CALL LIMITER	118
VOICE MAIL SYSTEM (OM-VML CARD)	119
USING YOUR MAILBOX	119
<i>SET UP</i>	119
<i>YOUR MAILBOX WILL GIVE YOU THE FOLLOWING LIST OF OPTIONS:</i> 119	
1 - <i>LISTEN TO NEW MESSAGES</i>	119
2 - <i>SEND A NEW MESSAGE</i>	119
3 - <i>CHANGE PASSWORD</i>	120
4 - <i>RECORD GREETINGS</i>	120
5 - <i>RECORD NAME AND SETUP DIAL BY NAME</i>	120
6 - <i>SET PAGER NOTIFICATION</i>	120
7 - <i>REMOTE NOTIFICATION (CELL PHONE)</i>	120
8 - <i>ASSISTANT EXTENSION</i>	120
9 - <i>DIRECT MESSAGE DELIVERY</i>	121

0 - REROUTE CALLER TO ANOTHER EXTENSION.....	121
* - CLIPBOARD RECORDING (ONE TOUCH RECORD).....	121
# - EXIT.....	121
LISTENING TO MESSAGES	121
1 - LISTEN	122
2 - SAVE	122
3 - DELETE.....	122
4 - REPLY	122
5 - HEAR THE HEADER INFORMATION	122
6 - COPY THE MESSAGE TO ANOTHER MAILBOX.....	122
* - SKIP THIS MESSAGE AND SAVE IT AS NEW.....	122
# - EXIT AND RETURN TO PREVIOUS MENU	122
SECTION 5 – DOORPHONE USER GUIDE	123
DOORPHONES.....	125
NOTES:.....	126

OMEGA-PHONE 924

TABLE OF CONTENTS - x

**Section 1 –
Omega-Phone 924
General Description**

OMEGA-PHONE 924

GENERAL DESCRIPTION - 2

FCC REGISTRATION AND REQUIREMENTS

INSTRUCTIONS TO THE USER

The Omega-Phone 924 digital telecommunications system has been registered and approved by the Federal Communications Commission (FCC) for direct connection to your local telephone service. In accordance with FCC rules and regulations regarding telephone equipment, Iwatsu is required to make you aware of your rights and obligations regarding the use of this equipment. In order that we may fulfill our obligations, please take a moment to carefully read the rules and regulations contained herein that apply to you.

NOTICES

The contents of this manual are subject to change without notice and do not constitute a commitment on the part of Iwatsu America, Inc. Every effort has been made to ensure the accuracy of this document, however, due to ongoing product improvements and revisions, Iwatsu America, Inc., cannot guarantee the accuracy of printed material after the date of publication nor can it accept the responsibility for errors or omissions. This document will be updated and revised as needed.

Reproduction, publication, or duplication of this manual, or any part thereof, in any manner, mechanically, electronically, or photographically, is strictly prohibited.

Warning: This service information is designed for experienced repair technicians only and is not designed for use by the general public. It does not contain warnings or cautions to advise non-technical individuals of potential dangers in attempting to service a product. Products powered by electricity should be serviced or repaired only by experienced professional technicians. Any attempt to service or repair the product or products dealt with in this service information by anyone else could result in serious injury or death.

The information contained in this document is subject to change without notice and should not be construed as a commitment by Iwatsu America, Inc. Iwatsu America, Inc., reserves the right, without notice, to make changes to equipment design as advances in engineering and manufacturing methods warrant. The software and hardware described in this document may be used or copied only in accordance with the terms of the license pertaining to said software or hardware. Reproduction, publication, or duplication of this manual, or any part thereof, in any manner, mechanically, electronically, or photographically, is prohibited without permission from Iwatsu America, Inc.

This equipment generates, uses, and can radiate radio frequency energy, and if not installed and used properly, that is, in strict accordance with the instruction manual, may cause interference to radio and television reception. This equipment has been tested and found to comply with the limits for a Class A computing device in Subject J of Part 15 of FCC Rules, which are designed to provide reasonable protection against such interference. However, there is no guarantee that interference will not occur in a particular installation.

If this equipment does cause interference by one or more of the following measures:

- Reorient the receiving antenna.
- Relocate the key service unit and key telephones with respect to the receiver.
- Move the equipment from the receiver.
- Plug the key service unit into a different outlet so that the equipment and receiver are on different branch circuits.

FCC INFORMATION

Provide the Telephone Company with the following FCC information:

ITEM	SPECIFICATION
Type of Service	The system is designed for use with standard telephone lines. Direct connection to party lines or coin-operated phones is prohibited.
FCC Registration Number	D6XMF00B924
Ringer Equivalence	0.0B
Network Address Signaling	Code E
Service Order Code	9.0F
Facility Interface Code	02LS2
Required Network Interface	Code RJ11C

Omega-phone 924 System Overview

This Key Telephone System has a modular single shelf flat-pack design which comes configured with **3 Central Office lines** by **8 Digital Extensions** and **2 analog extensions**. This system can expand to **9 Central Office lines** by **24 Digital Extensions** and **4 analog extensions**. In addition, Omega-Phone 924 system comes equipped to receive Caller ID from the telephone company, if Caller ID is supplied. Any analog telephone with Caller ID capability will also receive Caller ID.

Additional components include an OM-OPT Option module which provides 2 analog ports, Background Music (BGM), 4 Relays, 4 Security Sensors, an External Paging Port, Loud Bell Contact, and one RS232c for SMDR, as well as an OM-DDPH Doorphone. An OM-VML 8 Port Flash Voice Processing System (VPS) is also available.

The following is a list of available models and their corresponding part numbers:

Part Number:	Model:	Description:
700400	OM-KSU	3x8 Base Cabinet
700401	OM-308	3x8 Expansion Module
700405	OM-OPT	Option Module: Provides 2 additional Analog ports, BGM, Relays, SMDR, Page Port, and Loud Bell Contact
700410	OM-KTD30	Digital Display Telephone: 3-Line LCD Digital Speakerphone with Handsfree Communications
700419	OM-DDPH	Integrated Door Phone with Handsfree Response
700420	OM-VML	8 Port, 6 Hour, Integrated Flash Voice Mail with Auto Attendant
700430	OM-8WRLS	Base station, battery charger, and 6-line wireless office station.

SYSTEM HARDWARE

OM-KSU

An external power supply provides power for this stylish compact cabinet and main board which is equipped to operate 3 Central Office lines, 8 Digital Extensions, and 2 Analog ports. The additional 3 x 8, option module, and voice mail modules connect to the main board using a special **Mate Lock** connector and flat ribbon cables. Once powered up, the system will automatically identify each additional module that is installed.

The figure below shows how the additional modules are installed.

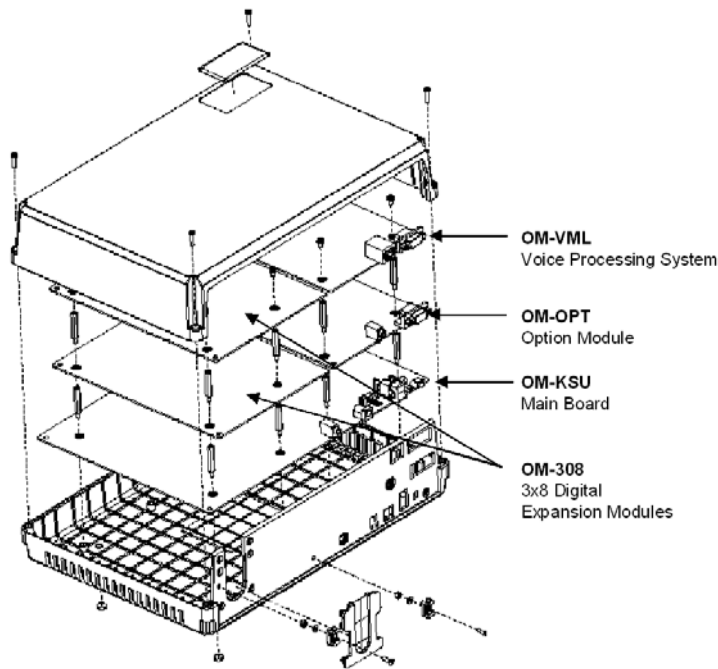

OM-KSU with Additional Modules

System Peripheral Connections

The system is equipped with many of the necessary peripheral connections required to operate other resources in conjunction with the system.

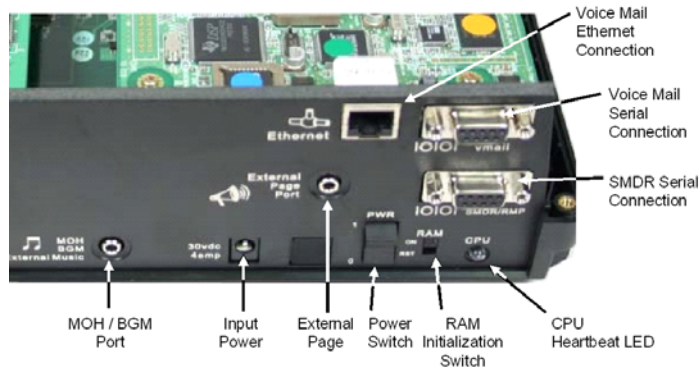

OM-KSU with Peripheral Connections

Configuration Options

At default, the system comes equipped with 3 Central Office Lines, 8 Digital Extensions and 2 Analog Extensions, but because of the modular design the system can be equipped with affordable modules to increase the system size to a maximum of 9 Central Office Lines, 24 Digital Extensions and 4 Analog Extensions. In addition, an 8 port integrated Voice Mail System can also be added.

The following table describes the building block structure of the system:

Configuration	Base	Maximum	Description
Digital Station Ports	8	24	OM-KSU equipped with 8 digital station ports. OM-308 card required to provide additional 8 digital station ports to maximum combined 24. Total combined number of OM-KTD30 + OM-8WRLS cannot exceed 24. Total number of OM-8WRLS handsets cannot exceed 2. 1 base station supports 1 OM-8WRLS handset.
OM-KTD-30 Digital Telephones	8	24	
OM-8WRLS Wireless Stations	0	2	
Analog CLID Trunk Ports	3	9	OM-KSU equipped with 3 analog CLID trunk ports. OM-308 card required to provide additional 3 analog CLID Trunk ports to maximum 9.
Single-Line Telephone (SLT) Ports	2	4	OM-KSU equipped with 2 SLT ports. OM-OPT card required to add 2 additional SLT ports. Caller ID supported.
Door Phones	0	2	Requires OM-OPT card. OM-OPT SLT ports used for door phones.
Voice Mail Ports	0	8	OM-VML provides 8 VM ports with 6 hours storage.
MOH/BGM Port	1	1	Included on OM-KSU.
External Page Port	0	1	Requires OM-OPT.
SMDR Port	0	1	Requires OM-OPT.

OM-KSU Main System KSU

The basic system comes with a power supply, and a motherboard configured for 3 CO lines, 8 digital stations, and 2 analog station ports. The Motherboard has an integrated Main Distribution Frame (MDF) designed to eliminate costly ancillary products, such as M66 split blocks, and is used like a patch panel.



OM-KSU

- Common control circuit with 80188 CPU.
 - Memory span: 1 MB ROM, 512KB RAM.
 - 3 analog CO line ports plus 1 Power Failure port on port-1.
 - Dual mode Caller ID detection (FSK and DTMF).
 - Caller ID (Type 1, FSK).
 - Built-in FSK transceiver for remote programming via digital extension.
 - DSP control for multi-party conference, tone plant, and tone detector.
 - External Music on Hold Connection using a mini-mono plug.
 - Battery Back Up for RAM.
- * System shown configured for 6 CO lines and 16 digital stations.

OM-308 Expansion Module 3 x 8

A 3 x 8 Expansion Module can be installed in the KSU, growing it from a 3 x 8 configuration to 6 x 16. Add an additional 3 x 8 Expansion Module brings the system up to its maximum capacity of 9 x 24.

Like the main board, each 3 x 8 Expansion Module comes with an integrated Patch Panel - MDF, making installation and Moves, Adds and Changes, quick and easy. Each Module is connected to the main board using a ribbon cable which is inserted into the E308 pin connector.

- Each OM-308 Module comes equipped with 3 CO (Central Office) connectors and 8 Digital Extension connectors.
- 3 analog CO line ports plus 1 Power Fail port on port-1.
- Dual mode Caller ID detection (FSK and DTMF).
- 8 Digital Extension ports.

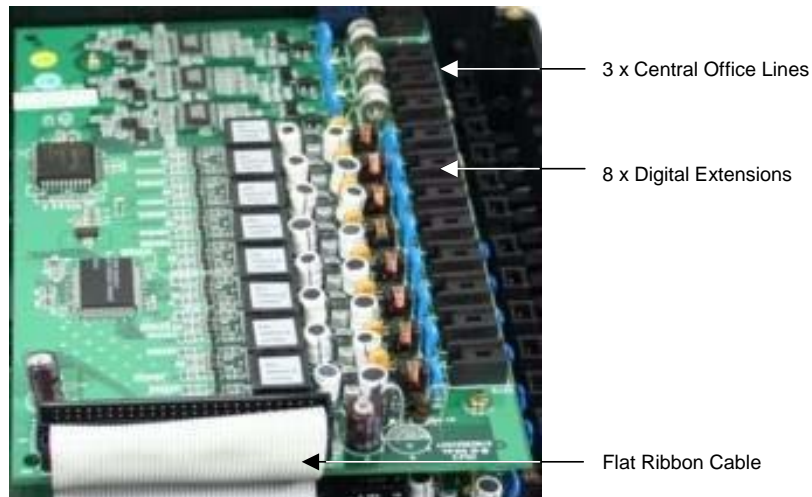

OM-308 3-Line x 8 Digital Extension Expansion Module

OM-OPT Option Module

The Option Module interfaces with the following ancillary devices:

- 2 Single Line Telephone Ports that can be programmed as doorphones.
- External Page Port to connect to an external paging unit (amplifier).
- Loud Bell Contact to connect an external bell or strobe light.
- RS232C (SMDR/RMP) Port to connect an SMDR Serial Printer, or Call Accounting Software.
- 4 – Door Relays which supply a momentary contact closure, which can be used to release an electronic door lock interface. Connects using a screw terminal interface.
- 4 – Door Sensors which are used to detect an opening of a device with a contact closure on it, such as an open door.

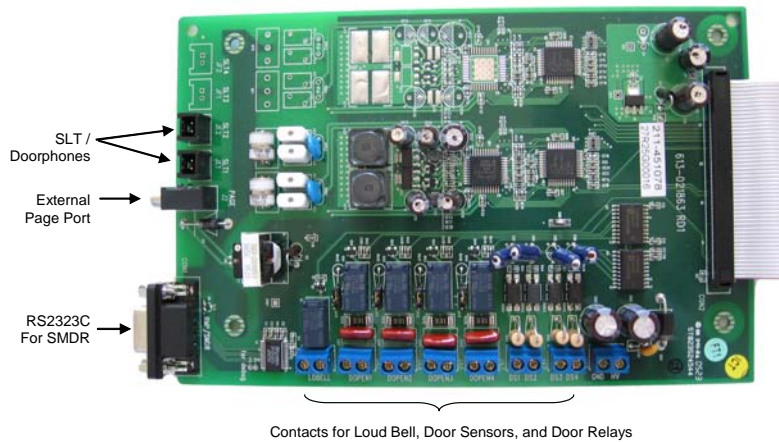

OM-OPT Option Module

The single line telephone ports do double duty and become door phones which can be programmed to integrate with a door opening relay and/or sensors. A ribbon cable connects the module to the motherboard and is inserted into the Option Board pin connector.

- Over-voltage Protection per CO Circuit.
- Polarity Guard per CO Circuit.

OM-VML Voice Processing System (Voice Mail Card)

An optional eight port voice mail module can be added to the Omega-Phone 924 system that delivers six hours of message storage. The Voice Processing System features live call screening, one-touch call recording, and cell phone notification. Voice mail messages can also be automatically sent to the user's email inbox so they can be accessed from a PC.

The OM-VML can be programmed to play greetings that include: Day, Night, Break, Holiday, Temp, Department, Extension, and Line greetings.

OM-VML Features Include:

- Automated Attendant.
- 8 Voice Mail ports.
- 256 MB Flash memory for 6 hours of recording time.
- Programmable Automated Attendant Greeting for each line.
- Message Notification and Forwarding: Cell phone and pager notification as well as Voice Mail message forwarding to a user's email address.
- Live call screening.
- One-touch call record.
- Pre-define up to 100 holidays. If recorded, the system will play a special Holiday greeting on the pre-defined holiday dates.
- Ethernet port for Administration Management.
- Programming interface: OM-KTD30 Digital Telephone and web browser.



OM-VML Voice Mail Card

OMEGA-PHONE 924 STATIONS

Digital and Wireless Telephones

These telephones have a combination of fixed and programmable features keys. Digital telephones are equipped with a digital display and have keys that provide red and green LED indication.

OM-KTD30 Digital Key Telephone

The OM-KTD30 digital key telephone is a high-quality, full-featured, speakerphone with programmable feature keys that allow the user to customize the operation of their telephone. The OM-KTD30 is equipped with navigation keys (located to the right of the display) that allow quick access to commonly used features.

The OM-KTD30 is equipped with three interactive soft-keys, six line keys, 12 flexible feature keys (the six line keys can also be programmed as flexible feature keys), and a three-line, 48-character LCD display. The OM-KTD30 has a large incoming call / MSG indication LED on the top of the telephone. This telephone also includes a headset jack and a pedestal that doubles as a wall mount to simplify installation.

OM-8WRLS 2.4 GHz Wireless Office Speakerphone

The OM-8WRLS Wireless Office Speakerphone was designed to allow you to move freely while maintaining access to any number of outside lines and the resources of your Omega-Phone 924 system. This telephone can be used for administrative and system programming as well as function in a hands-free environment.

The Omega-Phone 924 system supports a maximum of two OM-8WRLS wireless handsets using two base units. Each base unit supports one OM-8WRLS wireless handset.

ATTENDANT POSITION

The Attendant Position consists of an OM-KTD30 Key Telephone. Using the Attendant password, any OM-KTD30 or OM-8WRLS digital station can access the attendant feature set.

DOORPHONE

The Doorphone (OM-DDPH) provides an economical and simple method to allow visitors to make an intercom call to gain entrance to your building. The Omega-Phone 924 supports two doorphones.

SINGLE LINE TELEPHONES

Up to four industry standard single line telephones can be connected to the Omega-Phone 924. Caller ID is displayed on the SLT if supplied by the telephone company.

SPECIFICATIONS

SYSTEM CONFIGURATION

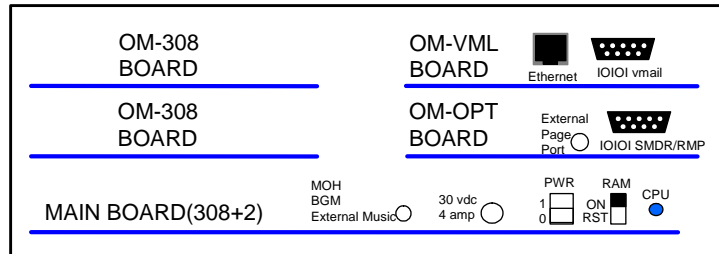

Power adapter: Full range VAC, Output 30VDC, 3A

Power Requirements

AC Power	110 or 220 VAC (Selectable)
Frequency	60 Hz
Power Consumption	100 Watts Max
Current Rating (Max)	1 Amp AC, 3 Amps DC
Loud Bell Contact	1 Amp DC (Do Not Use AC!)

Dimensions

KSU (OM-KSU)	12 1/2" L x 9 1/4" W x 3 7/8" H
---------------------	---------------------------------

Mounting

Mounting Methods	Wall Mount Table Mount
-------------------------	---------------------------

Operating Environment

Temperature	32 to 95 degrees Fahrenheit
Relative Humidity	5 to 90 % Non-Condensing

Wiring

Digital Telephone	2 Wire – Star Type
Single Line Telephone	2 Wire – Star Type

Maximum System Configuration

CO Lines with or without Caller ID (Analog)	3 – Main Board 3 – Each OM-308 Boards (Max of 2 OM-308) 9 – Maximum CO Lines in a fully-configured system
Digital Telephone Ports	8 – Main Board 8 – Each OM-308 Boards (Max of 2 OM-308) 24 – Maximum Digital Telephones in a fully-configured system.
Single Line Telephone Ports	2 – Main Board 2 – OM-OPT Option Modules 4 – Maximum SLT ports in a fully-configured system.
Option Module	1 – OM-OPT Option Module can be installed in the OM-KSU.
Doorphone	2 – OM-DDPH Doorphones can be installed in the System and take the place of the 2 SLT ports on the Option Module. At default, the doorphone ports are programmed to ring. If a doorphone is connected, but not programmed correctly, all inbound calls are automatically answered by the connected doorphone.
Voice Mail	1 – 8-port OM-VML Voice Mail Card can be installed in the OM-KSU.

CO Line Interface Specifications

Signaling	DC Loop
Dialing	Pulse / DTMF (Touch Tone)

Switching Technology

Digital	Time Division Multiplexing (TDM), Pulse Code Modulation (PCM)
----------------	---

Extension Interface Specifications

Dialing	Pulse or DTMF (Touch Tone)
Loop Length	80 Ohms for SLT Maximum
Ringer	70 VAC, 35 Hz SLT

Maximum Cable Length – Digital Extension Wiring

26 AWG	650 Feet
24 AWG	1133 Feet
22 AWG	1586 Feet

Maximum Cable Length – Single Line Telephone Wiring

26 AWG	850 Feet
24 AWG	1416 Feet
22 AWG	1983 Feet

OMEGA-PHONE 924 FEATURES

This section lists the major system features available on your Omega-Phone 924 telephone system. For detailed feature information refer to the Digital Telephone and Single Line Telephone User Guide sections in this manual.

911 Support	Extension Password / Phone Lock
Accessing Specific CO Lines	Extension Pick Up Groups
Account Code	Extension Reminder
Answering Machine Emulation	Flash – Telephone Company Line
Authority Code (Traveling Class of Service)	Flexible Feature key Programming
Auto Attendant Transfer to Busy Extension	Flexible Call Forward Timers
Automatic Hold	Forced Intercom Tone Ring
Automatic Selection (CO/Intercom)	Group Call Pickup
Background Music (BGM)	Headset Jack
Barge-In (Intrusion)	Hold, System (Common) & I – Hold Indication
Busy Lamp Field (BLF) / Direct Station Select (DSS)	Hold - Remind Time
Busy Ring Allow/Deny	Holding Call Answer – Select
Call Attendant (Operator)	Hot Key Enable / Disable
Call Back – Extension	Hunt Groups
Call Forward an Extension	- Linear Hunt
One Touch Call Forward:	- All Ring
Call Park / Call Park Answer	Voice Mail Hunt Group
Call Pickup Group	Intercom Calling - Non Blocking
Caller Identification - Call Log	- Intercom Key
Call Screening	Intercom Call Back
Call Waiting	Last Number Redial
Conference	Least Cost Routing
Data Rate	Message Notification
Day and Night Modes	Message Waiting
Default Flexible keys	Multiple Message Waiting Keys per Extension
Default Settings	Monitor
Directed Call Pickup	Mute
Distinctive Ring	Off Hook Voice Announce
Do Not Disturb	On Hook Dialing (Hot Key Pad)
Do Not Disturb - Override	One Touch Transfer
Enhanced Lettering Scheme	Page
Extension Feature Status Check	- Page (Allow / Deny)
	- Page (Meet Me)

Pause / Pause Insertion	Speed Dial (ABBR) – Extension
Phone Lock / Unlock	/System
Private To (Private Line)	Status Message
Pulse to Tone (DTMF)	Text Messages
Conversion	Touch Tone On/Off
Recall	Transfer
Reminder Tones	Transfer Beep
Ringing Level / Muted Ringing	Voice Announce / Hands-free
Ringing Line Priority	Reply
Relay Control	Voice Call Recorder (One Touch
Save Dialed Number (SDN)	Record)
Single Line Telephone - Flash	Volume Control
Simplified Remote Programming	Warning Tone / CO Line Call
Speakerphone	Limiter
Security Control	

OMEGA-PHONE 924

Section 2 – Digital Telephone User Guide

OMEGA-PHONE 924

DIGITAL TELEPHONES

These telephones have a combination of fixed and programmable feature keys. The telephones have red and green LED indicators.

OM-KTD30 SPEAKERPHONE WITH NAVIGATION KEYS

The Omega-Phone 924 OM-KTD30 digital telephone is a high quality, full featured speakerphone with programmable feature keys that allows you to customize the operation of your desk telephone.

OM-KTD30 Features

- 3-line 48-character display.
- 18 dual-color, programmable feature keys.
- 4-point navigation and select buttons.
- High quality speakerphone.
- 3 interactive soft-keys.
- 6 fixed keys - Hold, Transfer, Conference, Redial, Mute, and Speaker.
- 12 quick access speed dial keys.
- Built in headset jack (2.55 mm).



Omega-Phone 924 OM-KTD30 Digital Telephone

OM-8WRLS WIRELESS TELEPHONE

The OM-8WRLS was designed to function similar to the OM-KTD30 digital display telephone with the mobility of a wireless environment. The handset has a hot keypad, allowing telephone numbers to be dialed without having to press the Talk or Speaker keys and can be used for hands free communication.

The OM-8WRLS wireless handset is equipped with three interactive soft keys, six programmable feature keys, and seven fixed keys –including the volume control keys and speaker key which are found on the sides of the handset. To make the most of the OM-8WRLS wireless handset, it also comes equipped with a 1/8 inch (2.5 mm) headset jack and can be programmed to ring, vibrate, or ring and vibrate for each incoming call, making the OM-8WRLS one of the most versatile key telephones available for businesses today. The transmission frequency of the OM-8WRLS is 2.4 GHz.

The Omega-Phone 924 system supports a maximum of two OM-8WRLS wireless handsets using two base units. Each base unit supports one OM-8WRLS wireless handset.



OM-8WRLS Wireless Key Telephone and Base Unit

OM-KTD30 FEATURES



Omega-Phone 924 OM-KTD30 Digital Key Telephone Features

Basic elements of the OM-KTD30

- 3-line 48-character display.
- 18 dual-color, programmable feature keys.
- 4-point navigation and select buttons.
- High quality speakerphone.
- 3 interactive soft-keys.
- 6 fixed keys - Hold, Transfer, Conference, Redial, Mute, and Speaker.
- 12 quick access speed dial keys.
- Built in headset jack (2.55 mm).

Interactive Keys

Each digital telephone has 3 interactive soft-keys. Key operation changes as the telephone is being used. For example, when the telephone is idle, the center interactive key is labeled **cid**. If Caller ID is a service that is provided and the associated key is pressed, they station will display the last inbound Caller ID telephone number received.



When an intercom call is placed, and the remote telephone is ringing, three interactive keys update:

- Interactive key 1 - **cbck** = Call Back.
- Interactive key 2 - **msg** = Send an Alert Message.
- Interactive key 3 - **vm** = Leave a voice mail message.



Navigation Keys

The Navigation keys, located at the right of the Display, allows quick access to commonly used features. There are four Navigation keys which circle the Select key. For example, to use the Navigation keys, begin by pressing the right Navigation key, to access Call Log, and then press the down Navigation key to view incoming and the up Navigation key to view outgoing calls. Press the center Select key to dial the displayed telephone number.

Press the left Navigation key to scroll forward, and the right to scroll backwards through the Navigation feature list.



OM-KTD30 Interactive Soft Keys and Navigation Keys

Navigation Keys

Feature	Navigation	Result
Call Log	Up – Outgoing Numbers Down – Incoming Numbers	Press the Select key to dial the displayed telephone number.
System Speed Dial	Up – Access Bins 99 – 20 Down – Access Bins 20 - 99	Press the Select key to dial the displayed telephone number.
Feature Code List	Up – Directory List Down – Feature List	Press the Select key to select between Directory and Feature. Press down key to scroll forward, and the up key to scroll backwards through the selected list.
Call Extension	Up – Scroll from highest to lowest Down – Scroll from lowest to highest	Press the Select key to dial the displayed telephone number.
Page	Up – All Call Page Down – Page Groups 1 - 6	Press the Select key to page the displayed Page Group or All Call Page.
Music	Up – N/A Down – N/A	Press the Select key to enable or Disable Background Music.
Doorphone	Up – Answer Doorphone 1 Down – Answer Doorphone 2	The Doorphone must be connected and active to access.

GETTING STARTED

Idle Telephone Screen

Without the optional OM-VML Voice Mail Card:



Display Definition

MAY	Month
1	Day
MON	Weekday
10:00	Time
NO VMAIL	Voice Mail not installed
JOHN	Extension name
cid	Caller ID log
10	Extension number

With the optional OM-VML Voice Mail Card:



Display Definition

MAY	Month
1	Day
MON	Weekday
10:00	Time
VMAIL N:01 S:02	New 1 msg / Saved 2 msgs
JOHN	Extension name
cid	Caller ID log
10	Extension number

MAKING CALLS

Intercom Calls

All calls can be made from an idle telephone, there is no need to press the SPKR key or lift the handset. Once connected, lift the handset to converse privately. From an idle telephone, press the pre-programmed key or dial the extension number.

Handsfree Operation



Ringing Operation

Press the pre-programmed key or dial the extension number. The **vm** selection requires the optional OM-VML Voice Mail Card.



Outside calls

All calls can be made from an idle telephone, there is no need to press the SPKR key or lift the handset. For an outside line, dial 9 or press a line key and dial the desired telephone number. Once connected, lift the handset if you wish to converse privately.

Speakerphone calling:

1. Dial **9** or press a Line key.



2. Dial phone number.



3. While talking, the display will show the following:



ENDING CALLS

Handset Calling:

Place the handset in the cradle to terminate the call.

Speakerphone:

Press the SPKR key to terminate the call. When the Speaker light is extinguished the call is terminated.

SWITCHING FROM HANDSET TO SPEAKERPHONE

While the handset is off hook:

1. Press the speaker key.
2. The speaker key will light but there will be no sound.
3. Place the handset into the cradle.
4. Speakerphone is active.

Note: Switching from handset to speaker could cause a short squeal. To eliminate this possibility press the **MUTE** key first. The Headset must be disabled before the speaker will operate.

FEATURE OPERATION

FEATURE CODES

Feature codes may be dialed at the time of operation or they may be stored on a programmable feature key. Once stored, the feature can be easily accessed by pressing the key. If applicable, the associated LED will light, indicating that the feature is currently operational. For example, program Do Not Disturb on a feature key, when pressed, the associated LED will illuminate, indicating that the extension is in DND mode.

For Single Line Telephones, the # key is used in place of the Feature key.

Feature Code Table

Feature	Digital Telephone	Single Line Telephone
Access Specific CO Lines	<i>Feature 0(x) (x=line 1-9)</i>	# 0(x)
Account Code	4	4
Answering Machine Emulation (AME)	<i>Feature 64</i>	
Attendant	0	0
Attendant Administration	<i>Feature #0</i>	
Authority Traveling Code (Traveling CoS)	<i>Feature 55</i>	# 55
Automatic Hold (Allow/Deny)	<i>Feature 94</i>	
Automatic Selection	<i>Feature 95</i>	
Automatic Record	<i>Feature 67</i>	
Background Music (BGM)	<i>Feature 52</i>	
Busy Ring (Allow/Deny)	<i>Feature #2</i>	
Call Back	<i>Feature 91</i>	# 91

Feature Code Table (Continued)

Feature	Digital Telephone	Single Line Telephone
Call Forward	<i>Feature 2</i>	# 2(y) Y = 0 – Idle Forward 1 – Busy Forward 2 – Direct Forward 3 – Follow Me 4 – No Answer 5 – Busy / No Answer 6 – External Forward
Call Park	<i>Feature 73</i>	
Call Pickup Directed	<i>Feature 53</i>	# 53
Call Pickup Group	<i>Feature 54</i>	# 54
Caller ID (CID)	Press CID (Center Interactive Key)	
Call Wait (Allow/Deny)	<i>Feature 99</i>	
Camp On (Busy Extension)		Ext + 2
Camp On (Busy CO Line)		#
CO Line Access	9	9
Conference	<i>Feature 60</i>	
Data Rate	<i>Feature 75</i>	
Day/Night Mode (Attendant or Alt Attendant Only)	<i>Feature 63</i> + PPPP PPPP = Attendant Pswd	
Default Flexible Keys	<i>Feature 58</i>	
Default Setting	<i>Feature 69</i>	
Directed Call Pickup	<i>Feature 53</i>	# 53
Distinctive Ring	<i>Feature #7</i>	

Feature Code Table (Continued)

Feature	Digital Telephone	Single Line Telephone
Do Not Disturb	<i>Feature 4</i>	# 4
Extension Feature Status	<i>Feature #8</i>	
Extension Password / Phone Lock	<i>Feature 97</i>	# 97
Extension Reminder	<i>Feature 92</i>	# 92
Extension Reminder Delete	<i>Feature *92</i>	# *92
Flash (PBX/CO)	<i>Feature 3</i>	# 3
Flexible Feature Key Programming	<i>Feature #3</i>	
Group Call Pickup	<i>Feature 54</i>	# 54
Headset	<i>Feature 9#</i>	
Hot Dial	<i>Feature #6</i>	
Hold Retrieve (SLT) Same Extension		* 6
Hold Retrieve (SLT) Different Extension		* 7 EE EE = Extension
Hot Line		# #4
Intercom Callback	<i>Feature 91</i>	
Last Number Redial	<i>Feature 8</i>	# 8
Least Cost Routing	<i>Feature 68</i>	
Message Waiting	<i>Feature 96</i>	# 96 Send # *96 Cancel
Monitor Extension	<i>Feature 7*</i>	
Multiple Mailbox Key	<i>Feature 66 + 0 or Feature 66 + 70 – 79</i>	
Mute	<i>Feature 76</i>	
Night Mode (Attendant)	<i>Feature 63</i>	

Feature Code Table (Continued)

Feature	Digital Telephone	Single Line Telephone
Page	<i>Feature 50</i>	# 50(Z) Z = 0 – All Call 1 – External Page Only 2 – System All Call 3 + g – Group All Call (g = 1-9)
Page (Allow/Deny)	<i>Feature #9</i>	
Page Answer (Meet Me)	<i>Feature 59</i>	# 59
Pause	<i>Feature 70</i>	
Phone Lock	<i>Feature 97</i>	# 97
Pulse to Tone	*	*
Relay Control	<i>Feature 61</i>	
Saved Dialed Number	<i>Feature 51</i>	
Security Control	<i>Feature 62</i>	
Speed Dialing (Abbreviated Dialing)	<i>Feature 1</i>	
Speed Dialing (SLT)		# 1 to store * 1 to dial
Status Message	<i>Feature 90</i>	
Touch Tone On/Off (Dial Confirmation Tone)	<i>Feature #1</i>	
Transfer Beep	<i>Feature 79</i>	
Voice Call (Allow/Deny)	<i>Feature 98</i>	
Voice Mail	<i>Feature 64</i>	# 64
Voice Recording	<i>Feature 67</i>	

911 SUPPORT

At default, the Omega-Phone 924 is programmed to automatically contact your local Public Safety Answering Point (PSAP) when 911 is dialed.

ACCESSING SPECIFIC CO LINES

Feature 0(x)

To access an available line dial **9** or to access a specific line press the line key or press the Feature key followed by 0(x), where (x) = the Line 1 - 9. This allows both single line and digital key telephones the ability to access specific outside lines rather than dialing the line group code.

Conditions

1. The telephone company (CO) line must be connected to the telephone or company facility or error tone will be heard.

ACCOUNT CODE

4

Account Codes are passwords that are verified in the database and are used for two different reasons. The first reason is to grant different dialing privileges: When a valid Account Code is entered, for example, it may temporarily grant access to long distance dialing. The second reason is to create a record: With the use of Station Message Detail Recording (SMDR), extensions may be forced to use Account Codes before dialing out on any telephone company line or it can be voluntary. All Account Codes are verified.

ANSWERING MACHINE EMULATION

Feature 64

Answering Machine Emulation requires the Voice Mail (OM-VML) card. This feature mimics the call screening feature of a home answering machine. When a caller is answered by your voice mailbox, you will have an opportunity to monitor/screen the caller as they leave a message.

You will receive a warning tone that indicates when a caller has been answered by your voice mailbox.

1. Press the voice mail key when it is flashing green.
2. Select monitor call to listen to the caller.
3. Select answer to retrieve the caller or press exit to allow the caller to leave a voice mail message.

Conditions

1. To Monitor or answer a call, action must be taken before the Monitor Time expires.
2. The Monitor Time starts at the time the caller is connected to the user's voice mailbox.
3. For Answering Machine Emulation to operate, the extension must be forwarded to the voice mail system.
4. Predefined Call Forward or Extension Call Forward can be used for this purpose.

AUTHORITY CODE (TRAVELING CLASS OF SERVICE)

Feature 55

Authority Codes are used to enable a higher Class of Service to an extension with a lower Class of Service. When using Authority Codes, the extension password must be entered.

1. Enter **Feature 55**.
2. Enter your **extension** number.



3. Press **save**.
4. Enter your four-digit extension **password**.



5. Press **save**.



Conditions

1. Error tone is heard when an invalid account code is entered, and the telephone will return to an idle state.
2. When a valid account code is dialed, the extension connects to a CO line, and the Account Code CoS is verified before a call is placed.

AUTOMATIC HOLD

Feature 94

This feature helps eliminate accidental lost calls by automatically placing the current call on hold, while answering another CO line call. For example, when a user is on CO Line 1, and presses CO Line 2, CO Line 1 will be placed on Exclusive Hold automatically. Similarly, (while talking with another extension) by pressing a CO line key, the intercom call is placed on Exclusive Hold. The need to press Hold is eliminated, except if you want to place a call on System Hold.

Conditions

1. The Feature Code (**Feature 94**) may be programmed under a flexible key on a digital speakerphone. To enable/disable the feature, press the flexible key.
2. If you access an idle line and skip to another line before dialing, the first line will not be automatically placed on Hold. (Once a digit is dialed, the line is consider in use, so the Automatic Hold feature is active.)
3. The Automatic Hold feature places a call on Exclusive Hold.
4. If you have the Automatic Hold feature programmed on a feature key, the feature key lamp will light when the feature is enabled.

AUTOMATIC SELECTION (CO/INTERCOM)

Feature 95

This feature automatically selects a specific outside line or intercom (ICM) when the handset or the speakerphone key is pressed.

1. Press **Feature 95**.
2. Press **chg** to select the action you would like when your telephone goes off hook.



Selections are:

- ICM = Intercom (Default)
 - OUTG TR = Any outgoing telephone line
 - LINE 1 = A specific telephone line (1 ~ 9 depending on the system configuration)
 - GROUP = Line Group 1 - 6 (Default is Line Group 1)
 - NULL = No off hook action
3. Exit programming.

Conditions

1. A line will not be accessed automatically when a telephone is receiving an incoming call (outside or intercom) call or when a line is recalling at the telephone. However, this operation may be override by pre-selecting an outgoing line, or dialing an extension before lifting the handset or pressing the speaker key.
2. The system will not allow invalid directory numbers to be programmed during setup
3. An Extension must have CO line access to any CO line or line group trying to be accessed.

BACKGROUND MUSIC (BGM)

Feature 52

The system comes equipped with one external music source input for Music On Hold (MOH) and Background Music (BGM). When a digital telephone is idle and this feature is activated, the user can monitor background music (BGM) through the telephone speaker. This feature can be activated using a feature code or by pressing the programmed feature key (**Feature 52**). In addition, the navigation keys can be used to enable / disable the MOH feature.

Conditions

1. The feature key LED will not light when BGM is activated.
2. BGM automatically turns off when an extension user receive or make a call.
3. BGM automatically turns on again when the telephone returns to an idle status.
4. Users with BGM enabled will not hear a system alarm reminder.

BARGE-IN (INTRUSION)

See Intrusion - Extension

BUSY LAMP FIELD (BLF) / DIRECT STATION SELECT (DSS)

Depending on user requirements, any Programmable Feature key can be programmed as a Busy Lamp Field (BLF) key to monitor an extension's status. When an extension is off hook the programmed BLF key LED for that extension lights. When that extension is in Do Not Disturb, the LED will flash. This same key is used as a one-touch Direct Station Selection (DSS) call key for quick transfer of calls or intercom calling.

Use the following steps to program a flexible key:

1. Press **Feature #3**.
2. Press the feature key to be changed.



3. A description of the current programming will be displayed for three seconds.



4. To modify the key, press **chg** within the three seconds.



5. Select between **line**, **ext** or **feat**.
 - **line** - 1 - 9 (depending on the configuration).
 - **ext** - Any valid extension in the system.
 - **feat** - Any valid feature, must press the feature key first.
6. Exit programming.

Conditions

1. BLF/DSS keys may be assigned to any of the 18 User Programmable Feature Keys.
2. Extensions in Do Not Disturb mode will cause the LED associated with that extension to flash.
3. Extensions that are busy will cause the LED associated with that extension to light steady.
4. The DSS function can be used to transfer calls to other extensions.

BUSY RING ALLOW/DENY

Feature #2

This feature allows the extension user the ability to turn on or off muted ringing of incoming or transferred calls when the user is in a busy status. When a telephone line is ringing or transferred to a busy extension and Busy Ring is allowed, the user will hear muted ringing. When a telephone line is ringing or transferred to a busy extension and Busy Ring is denied, the user will hear a single burst of warning tone. All programmed call forwarding and recall conditions apply in either Busy Ring condition.

Conditions

1. This feature will toggle on/toggle off when it is programmed under a flexible key on the Digital Speakerphone.
2. The LED will not light when the feature is enabled, or disabled.

CALL ATTENDANT (OPERATOR)

0

The extension that is programmed as the Attendant may receive multiple internal calls via the Operator Code **0**.

Conditions

1. The Operator Code (0) is in addition to the default assigned two-digit intercom number for the extension.
2. The attendant two-digit extension number can be assigned to any feature key.

CALL BACK – EXTENSION

Feature 91 or press cbck

This feature allows the user to queue an extension which is busy, in Do Not Disturb (DND) or idle. When a user sends a Call Back to a busy extension, the Call Back process will begin when the busy extension hangs up. When Call Back is sent to an idle extension, the Call Back process will begin once the user performs an operation at that extension and then hangs up.

When the Call Back process begins the user will hear bursts of tone signaling them to pick up the handset or press the LCD soft key under **reply**. Then the queued extension begins ringing.

Conditions

1. If the user presses [del] during the Call Back Alert ringing, the Call Back will be cancelled and the display will read **CBCK DELETE**. The extension returns to an idle status.
2. To invoke a Call Back at an extension that is in the Voice Announce mode, the user must press Force Tone Ringing (*).
3. When a Call Back alert is not answered at the extension that invoked the Call Back, the display message **CBCK TO Ext xx** (xx=extension number) is displayed until either they **reply** or **del**.
4. The Call Back process begins when both the user's extension and the called party's extension are idle, on-hook.

CALL FORWARD

Feature 2

There are several call forward options to choose from so that each extension user can customize their own call forwarding.

- **Idle** - Forward calls when the station is idle.
- **Busy** - Forward calls only when the extension is busy.
- **Direct** - Forward all calls directly to a new destination without ringing the extension first.
- **No Answer (na)** - Forward calls that go unanswered at an extension.
- **Busy / No Answer (bsy/na)** - Forward calls when the extension is busy and when calls go unanswered.
- **Follow Me** - Use the follow me feature to receive calls at a temporary location and activate the feature remotely from another extension.
- **External** - Forward incoming calls to another location or different telephone number. (This feature must be enabled for your extension in database administration.)

Forward conditions may be set as follows for each call forward type:

- Intercom calls only.
- Intercom and CO Line calls (including transferred CO Lines).
- CO Line calls only.

1. Press Feature 2.



2. Select **idle** to forward all calls when the phone is idle or select **busy** to forward calls only when the extension is busy. Select **next** for more options.



3. Select **direct** to forward all calls directly to a new destination without ringing the extension first or select **na** (no answer) to forward telephone calls only when the extension does not answer. Press **next** for more options.



4. Select **bsy/na** to forward calls when the extension is busy or does not answer a ringing call or **ext** to forward calls to an external telephone such as a cellular or home telephone number. Select **follow** to (follow me) forward all calls to another extension such as a conference room.
5. Once selected, enter the destination that calls should be forwarded to, for example, voice mail or other destination. Press **save**.
6. Select the type of call to forward to the selected destination, **co** (outside) line, **icm** (intercom), or both **icm/co**.



7. Enter the No Answer time if no answer forwarding is being used. Valid entries are 10 - 50 seconds. Press **chg** to scroll through the timer options.



8. Press **save**.
9. A confirmation tone is heard and the telephone goes back to idle.

One Touch Call Forward:

This feature allows each extension user to program a flexible key which will, with one press, complete call forwarding.

The following table shows all of the feature codes which can be placed on a One Touch Forward key.

To begin:

1. Press **Feature #3** and then press the selected flexible feature key that you want to program (within three seconds) and press **chg**.
2. Using the codes on the following table, select the type of forwarding using the Forward Code number, the destination (such as voice mail) and select which type of call should be forwarded. When applicable enter the No Answer time.
3. The telephone will return to idle.

One Touch Forward Operation

Forward Type	Feature Code	Forward Code	Destination	ICM ICM/CO CO	No Answer Time	Entry Code
Idle	F 2	0	87 VM 10-37 Ext 82-89 Hunt Grp	ICM=1 ICM/CO=2 CO=3		F20872
Busy	F 2	1				F21872
Direct	F 2	2				F22872
Follow Me	F 2	3				F23872
No Answer	F 2	4			1=10 / 2=20 3=30 4=40 / 5=50	F248722
Busy/No Answer	F 2	5			1=10 / 2=20 3=30 4=40 / 5=50	F258722
External	F 2	6	Tele.No. *			

* External Call Forward requires a Pause at the beginning of the number. To enter a Pause, press **Feature 70**, which is replaced with a P

Conditions

1. Intercom calls to a forwarded extension will receive a special tone signifying that the extension called is forwarded.
2. The Auxiliary Lamp will not light in call forward mode if it has been disabled by the attendant in Attendant Administration.
3. If any of the Call Forward features are programmed on a flexible key, the LED associated with that key will light indicating that call forward is active.

CALL PARK / CALL PARK ANSWER

Feature 73

This feature allows calls to be placed in a **Park** location at any extension. It is also used to retrieve a parked call from the extension. Calls are parked and retrieved by dialing the Call Park code (Feature 73) followed by the extension number where the call was parked.

Call Park is similar to transferring a call to a hold location, that is accessible from any extension in the system.

Conditions

1. Each telephone/extension has one personal extension number used to park one CO Line call.
2. Any extension can park a call at another (installed) extension.
3. The Call Park feature code may be programmed on any programmable feature key.
4. Calls can be retrieved from any extension.
5. Parked CO Lines are on Transfer Hold at the extension that placed the call in Park and on Hold at the extension that parked the call.
6. Any extension can retrieve a parked CO line, even if the extension is normally not allowed to access or receive a call on that line.
7. A user that invokes Call Park Answer but does not have a CO line key for the line retrieved from Call Park may use Hold Call Answer to place the call on hold and retrieve the call from hold.
8. The Call Park Answer feature code may be programmed on any programmable feature key.
9. Calls that are parked follow the Transfer Recall Timer and will ring the initiating extension when that timer has elapsed.

CALL PICK-UP GROUP

Feature 53 / Feature 54

An extension can answer calls ringing at another extension by using the Call Pick-Up Group feature. This feature allows users to easily access calls ringing within a group by dialing the pick-up code or pressing the preprogrammed key.

If multiple calls are ringing at an extension, a priority list determines which call will be answered first.

Call Pick-Up Priority List:

- Camped-On CO Line Calls.
- Recalling CO Line Calls.
- Transferred CO Line Calls.
- Incoming CO Line Calls.
- Tone Ringing Intercom Calls.

Conditions

1. If the call at the dialed extension has stopped ringing, before the call is picked up, the user will hear error tone and the display on a digital speakerphone will show **PICKUP FAILURE**.
2. An extension that does not have the outside line appearing on a key or does not have CO Line Receive programmed may still answer the ringing line by the Call Pick-Up procedure.
3. The Call Pick-Up feature code may be programmed on any programmable feature key.
4. If several calls of the same priority are ringing at the extension, the calls are answered in the order they are received.

CALLER IDENTIFICATION - CALL LOG

Each extension is equipped with a Call Log that stores both inbound (received) and outbound (dialed) telephone numbers. Use the navigation keys to select the Call Log. Press the up button to view outgoing and the down button to view incoming calls placed to/from the extension. The Call Log numbers are stored in reverse order, from newest to oldest. If the name is not supplied, only the number is displayed, if the name is supplied, the name and number are displayed. Press the Select key to initiate a call back to the displayed telephone number.

Conditions

1. All OM-KTD30 telephones have a Caller ID Log.
2. If no name is delivered from the telephone company, only the number is displayed.
3. Proper programming of local area code(s) and the long distance prefixes are required to ensure accurate redialing of CID numbers from the Call Log.

CALL WAITING**Feature 99**

When Call Waiting is enabled and you are on a call, the user will hear an alert tone when an internal call is waiting. You can toggle the feature on and off when it is programmed on a Programmable Feature Key.

Conditions

N/A

CONFERENCE**Feature 60 or CONF Key**

The system can accommodate up to eight, four member (party) conferences simultaneously. All conferences require one extension and can support up to three additional CO line calls or extensions, to a maximum of four conference members.

Conditions

1. The extension that establishes the conference is the “initiator”. The “initiator” is the “controlling party” capable of adding additional CO line calls or intercom extensions to the conference.
2. While establishing a conference or privately talking to one party all extensions involved in the conference will be placed on Exclusive Hold.
3. If the initiator exits the conference the most recently invited, internal party, will automatically become the new controlling party.
4. If the Conference Tone is enabled, a burst of tone will be heard by all participants each time a new participant joins the conference.
5. A three party conference must be established before adding the fourth party. The initiator makes the first two calls, and places them on hold, then presses the CONF (Conference) key. This creates a three party conference. To add the additional conference member, the initiator presses hold, makes the final call, and presses the CONF (Conference) key.

DAY AND NIGHT MODES

Feature 63

The system can be programmed to follow a seven day, twenty-four hour time schedule that will automatically switch the system from Day to Night modes. These modes will affect the incoming call ringing assignment by sending them to their programmed day or night destinations. In addition, the Attendant can manually change the system from Day to Night mode. Doing so will leave the system in that mode until it is manually changed. The Feature code (Feature 63) is used to toggle between these modes.

Conditions

1. At default, no CO lines (outside lines) are programmed to ring an extension.
2. The System Operation Mode must be set to **Time Mode** for the system to automatically switch from Day to Night mode ringing.
3. When programming Time Service Mode switching, the input time represents the time of day that the Service Mode will change to the associated Service Mode.

DEFAULT FLEXIBLE KEYS / FEATURE KEY RESET

Feature 58

Default Flexible Keys, also known as Feature Key Reset, allows the user to dial a code and bring all of the flexible keys back to factory default. This requires entry of a valid extension password.

DEFAULT SETTINGS

Feature 69

This feature is a quick way to deactivate any features which have been changed from factory default at an extension. For example, it will disable any call forwarding, DND, etc. with one entry code. Key programming is not defaulted.

Feature	Default Setting
LNR (Last Number Redial)	Empty
SNR (Saved Number Redial)	No Saved Number
Auto Hold	No
Phone Lock	No
Voice Call	Allow
Call Wait	Deny
Page Receive	Yes
Busy Ring	Yes
XFR (Transfer) Beep	Enabled
Touch Tone	Off
Headset	Disabled

Conditions

1. Flexible keys are not changed.
2. Any activated or deactivated feature is set back to default, but database parameters such as Class of Service, Predefined Forwarding etc., are not changed.

DIRECTED CALL PICKUP

See Call Pickup

DISTINCTIVE RING

Feature 7#

At default, all extensions ring the same way. However, each extension may select between four distinctive ring tones.

Conditions

1. The telephone must be idle when the code is entered.

DO NOT DISTURB

Feature 4

Extension users have the ability to place their extension in Do Not Disturb. When invoked, Do Not Disturb (DND) prevents all calls, intercom and CO line, from ringing at an extension in Do Not Disturb. DND may be activated while the telephone is in use or is idle. Extensions with a higher Class of Service (CoS) have the ability to override an extension's DND setting.

A short stutter tone is audible when DND is active. A digital telephone is capable of having the DND feature assigned to a programmable key that will light whenever DND is active. Other extensions with a programmed DSS/BLF key of the extension that is in Do Not Disturb will flash indicating that the extension is in DND.

Conditions

1. Do Not Disturb cannot be enabled when Station Call Forward is active.
2. To redirect a ringing call to the attendant, press the pre-programmed DND feature key while the call is ringing.
3. When an extension is in DND, all other extensions with a DSS/BLF for that extension will flash indicating that the extension is in DND.
4. The DND feature code may be programmed on a programmable feature key.
5. A feature key programmed for the DND code will light steady, on the extension that is in DND, whenever it is active.

DO NOT DISTURB - OVERRIDE

DND - Override is used to intercom an extension which has been placed in DND. At default no extension may override another extension that is in DND mode. If available to an extension, **override** is displayed on the LCD when an extension has activated DND. Press the associated interactive key to override DND.

Conditions

1. An extension in DND that has been overridden will tone ring indicating the override.
2. An extension in DND that has been overridden may invoke Forced Intercom Call Forward, which will redirect the call to the attendant.
3. The DND feature code may be programmed on a programmable feature key.
4. Only extensions with a higher Class of Service (**0 being the highest and 9 being the lowest**) may override an extension in Do Not Disturb.

ENHANCED LETTERING SCHEME

The Enhanced Lettering Scheme is used to accommodate special characters that may be needed when entering an extension user name or when editing any of the pre-programmed messages. There are six different lettering schemes to choose from, but only one can be selected for an installation. Use the **1** key to select one of the special characters, when entering a name or preprogrammed message.

Character for n th depressions of dial key "1".						
	1 st	2 nd	3 rd	4 th	5 th	6 th
Scheme 0	Æ	Œ	ø	Ø	á	Á
Scheme 1	Ç	Ā	Ō	Ń	Ā	Ă
Scheme 2	ò	é	é	è	à	ù
Scheme 3	č	š	é	ñ	ō	ř
Scheme 4	Á	É	Ó	Ú	Ú	
Scheme 5	Ł	Ż	Ŕ	Ŕ		

Conditions

1. Default Enhanced Lettering Scheme = **Scheme 0**.

EXTENSION FEATURE STATUS CHECK

Feature #8

Extension Feature Status Check allows digital telephone users to quickly view the settings and status for all user-controlled features. It is also a great troubleshooting tool for technicians, allowing them to determine the status of specific features which are programmable by the user. Press the interactive key associated with next to scroll through the following features.



Settings at default:

- LNR = Empty or the last number dialed
- SNR = No Saved Number
- Day CoS = 0
- Night CoS = 0
- Monitor CoS = 5
- Auto Hold = Deny
- Phone Unlocked
- Voice Call = Allow
- Call Wait = Deny
- Paged = Allow
- Busy Ring = Allow
- XFR Beep = Enable
- Data Rate = 9600
- Forced LCR = N (No)
- Touch Tone = Off
- ECF = Disable

Conditions

1. Listed above are the default (factory) values for each of the displayed features. Therefore, the actual values may appear different.

EXTENSION PASSWORD / PHONE LOCK

Feature 97

Each extension has a four-digit User Password which is needed to access certain features such as, Follow Me Forward, Authority Code, and Phone Lock.

Conditions

1. Default station password is 0000.
2. Each extension can customize their password at any time (Four digits maximum).
3. The password of the extension that is programmed as the Attendant, becomes the **Attendant Password** (default Attendant Password = 9999).

EXTENSION PICK-UP GROUPS

Feature 54

Extension Pick-Up Groups allow you to dial a code and pick-up an actively ringing call within your group. The digital telephone will give a short double-tone burst and update the display to read **PICK UP FAILURE** when attempting to pick-up a call that is not within your group

Conditions

1. Extensions may be assigned to only one Extension Pick-Up Group.
2. The pick-up priority for ringing calls are CO lines and then intercom calls.
3. CO line call priority is camped-on, recalling, transferred, and incoming.
4. Intercom call priority is ringing then voice calls.

EXTENSION REMINDER

Feature 92

Each extension has a private alarm that can be used to remind them of special appointments, events, etc. When the Extension Reminder activates, the user will hear ring tone for a programmable period of time ranging from 10 to 60 seconds. After the programmed period, the Extension Reminder is automatically canceled. The extension user can program the Extension Reminder to be activated once or always (repeated). When programmed for always, the Extension Reminder will sound at the same time everyday.

Conditions

1. The Extension Reminder feature code maybe programmed under any programmable feature key.
2. The alarm clock will be automatically canceled after the programmed Alarm Play Time.
3. The display will be unchanged until the **ack** (Extension Reminder acknowledge) interactive key is pressed or when the telephone is used for another call.
4. The Extension Reminder time is entered in military (24 hour) format. For example: 8:05pm is entered as 20:05.

FLASH – CENTRAL OFFICE (CO) LINE

Feature 3

Flash – Central Office Line is a programmed setting that will determine what flash timing will be presented to the telephone company central office when the user issues a Hook-Flash command while connected to a CO line. This feature is a requirement when the system is installed behind a Centrex or PBX system. For easy access it is recommended, in these two cases, the Flash feature code is programmed onto a Programmable Feature key.

If Call Waiting is provided, by the telephone company, the Flash feature is used to answer a second incoming call while connected to another outside party.

Conditions

1. The Flash code may be stored in any speed dial bin.
2. The Flash code may be stored in the Last Number Redial buffer.
3. The digital telephone will display a / to indicate the Flash.

FORCED INTERCOM TONE RING

When an extension is in Hands Free - Voice Announce mode, intercom calls will not forward, so the system allows callers to dial * to activate Forced Intercom Tone Ring which allows callers to ring the extension.

Conditions

1. It is not possible to force an extension from Tone Ring mode to Voice Announce mode if the extension is set to Tone Ring mode.
2. When an extension leaves a callback, the alert signal will ring.

GROUP CALL PICK-UP

Feature 54

See Call Pick-up

HEADSET JACK

Feature 9#

The headset jack on all digital speakerphones will accept industry standard 2.5 mm headsets. A headset connected to the headset jack operates as an integral component of the digital speakerphone. Once enabled, the speaker key acts as the on / off button for the headset operation.

Conditions

1. The headset jack can be found next to the handset jack on the left side of the telephone.
2. External headsets require that the handset be lifted each time a call is answered.

HOLD, SYSTEM (COMMON) & I – HOLD INDICATION

This feature allows the user to place any call on hold by pressing the Hold key. If the extension that placed the call on hold has a CO line programmed on a Programmable Feature key, the LED will light, and flash slowly. All other extensions with key appearances will be lit solid.

I – Hold Indication refers to the color difference of the LED's. When an extension places a CO line on hold, I – Hold identifies that the call is holding for that extension with a flashing LED. A CO line placed on hold by a different extension will change colors and is lit solid.

Conditions

1. When the conference initiator presses Hold, the conference parties will be placed on Exclusive Hold. This feature is used when adding conference parties. The LED will flash green at the conference initiator's extension.
2. Calls placed on hold will hear Music On Hold only if an external music source is connected.
3. Calls placed on Exclusive (private) Hold, which have exceeded the programmed **Exclusive Hold** time, will be automatically converted to System Hold.
4. There is a distinctive slow flash rate for a CO line that is on System Hold.
5. There is a distinctive rapid flash rate for a CO line that is on Exclusive Hold.

HOLD - REMIND TIME

When the programmable **Hold Reminder** timer is exceeded, a single ring tone is heard at the extension that placed the call on hold. This reminder is repeated each time the timer expires.

Conditions

1. Hold Reminder applies to both intercom and CO line calls.
2. Hold Reminder applies to CO line calls that are on System Hold or Exclusive Hold.

HOLDING CALL ANSWER – SELECT

Hold

Holding Call Answer - Select allows a user to place and retrieve calls on and off hold by pressing the Hold key. When several calls are holding at an extension, Holding Call Answer will access the CO line that has been holding for the longest period of time while placing the current call on hold.

Holding Call Answer works for all CO lines, regardless of the CO line key programming. It is possible to retrieve calls that do not appear on a key at an extension via Holding Call Answer.

Conditions

1. Holding Call Answer – Select also operates for intercom calls placed on hold.
2. If the person on hold hangs up, the system automatically releases the held CO line.

HOT KEY ENABLE / DISABLE

Feature #6

Hot Key is the automatic operation of dial pad keys while the telephone is idle. Once a digit is dialed from an idle extension, the digital telephone becomes active, and begins processing all digits dialed. For example, one extension can dial another just by dialing the extension number.

Conditions

1. It is not recommended to disable the Hot Key feature when Automatic Line Select (Prime Line Pickup) Feature 95 is set to a CO line or Line Group because it will make internal calling problematic.
2. If enabled, and the Feature key is the first key pressed, then the dial pad becomes active. Therefore, when activating a feature and the feature key is the first key pressed, there is no need lift the receiver.

HUNT GROUPS

82 - 89

There are eight Hunt groups that can be assigned for up to 24 members. There are three types of hunt groups: All Ring, Linear Hunt, and Voice Mail. Hunt groups 1 - 8 correspond to extensions (dial codes) 82 – 89. At default, Hunt group 6, Dial Code 87, is reserved for Voice Mail and already contains the voice mail extension numbers 56 - 63. Also, at default, Hunt groups 88 and 89 have all extensions preprogrammed into them, and Doorphones 1 and 2 (SLT Ports on the Option Module 36 and 37) are also programmed to ring those hunt groups.

Linear Hunt

Stations in a linear hunt group ring in the order in which they are programmed. If a member in the sequence is busy, the next available member will ring. If all members are busy, the caller will hear ring no answer. For instance, if Member 1 and Member 2 are busy, Member 3 will ring. As soon as the busy members are no longer busy, they are placed back into queue. When a pilot hunt group is dialed, the members are always called in sequence, always starting with Member 1.

All Ring

When the pilot number for an all ring hunt group is dialed, all idle extensions within the group will ring.

Voice Mail Hunt Group

The OM-VML Voice Mail card is required when programming a **vm** (voice mail) hunt group. The voice mail card must be installed to enable the system to process in-band signaling.

Conditions

1. Hunt group members are entered in the order that they will ring.
2. If the first entered extension is idle forwarded, it could cause all calls programmed to ring the hunt group to forward.
3. Calls that ring an idle extension will not following station forwarding.
4. When a call is presented to an all ring hunt group, and all extensions are busy, the caller receives a busy signal.

INTERCOM CALLING - NON BLOCKING - INTERCOM KEY

Intercom Calling (ICM) allows a user to place an intercom call by dialing the intercom number for another extension. A DSS/BLF key can be programmed for placing an ICM call by pressing one button. Hands-free intercom calls can be placed without lifting the handset. Background noise may restrict the suitability for hands-free connections.

Each extension is capable of independently selecting how intercom calls are received. The user can select either Voice Announce Hands-Free or Tone Ringing mode using Feature 98.

Conditions

1. Intercom calls to telephones in Voice Announce - Hands-free are logically answered by the system at the called extension. Therefore these calls cannot be picked up by other extensions using Group Call Pickup. Auto Line Selection is set to Intercom (ICM) at default. Intercom dial tone is heard automatically upon lifting the handset or when pressing the **Speaker** key. If a called extension does not answer you can invoke a callback to that extension by pressing the soft button under **cbck** on the display.

INTERCOM CALL BACK

Feature 91

The Intercom Call Back feature is used to queue for an extension that may be busy or unattended. The next time the telephone becomes idle, the Call Back feature automatically rings the telephone that initiated the Call Back feature. When the initiator presses the speaker key or lifts the handset, the extension that received the Call Back, automatically begins ringing.

Conditions

1. An extension can only initiate one Call Back.
2. No one extension can have more than five Call Backs in queue at one time.

LAST NUMBER REDIAL

Feature 8 or fixed redial key

Last Number Redial (LNR) allows the user to automatically dial the last number dialed from their telephone. The LNR feature will retain up to twenty digits for each extension. The user can select a specific CO line to be used with LNR by pressing that CO line key or you can allow the system to automatically select a line. Another way of using the last number redial is to use the Navigation keys, locate the **Call Log**, and then press the up arrow, to view a list of the last 50 outgoing telephone numbers dialed.

Conditions

1. Last Number Redial only works with CO (outside) calls.
2. When LNR is activated the system will first select the previously used CO line to dial. If that CO line is busy, any idle CO line in the same group is selected. If all CO lines are busy, a busy tone is heard and **ALL CO Lines BUSY** is displayed on the screen.
3. The LNR feature code can be programmed on a programmable feature key.
4. LNR will repeat a hook-flash in the same sequence as it was first dialed. If a speed dial number was first dialed, LNR will dial the speed dial number and any subsequent manually dialed digits.
5. If the Last Number Redial memory is empty, the telephone will receive error tone and the telephone will display: **LNR EMPTY**.

LEAST COST ROUTING

Feature 68

Least cost routing allows the system to evaluate each telephone number dialed to ensure that it is using the correct trunk route.

Conditions

1. This feature must be enabled in database programming.

MESSAGE NOTIFICATION AND FORWARDING

Stay connected to the office from anywhere. The voice mail system can be programmed with an external telephone number, like a cell phone or pager, and send notification of a new voice mail message in the user's office inbox. Voice mail messages can also be sent to the user's email inbox so they can be accessed from a PC.

Note: Requires the OM-VML Card.

MESSAGE WAITING

Feature 96

When you call a busy or unattended extension, you have the option to send a message waiting indication. You may select to use the first interactive soft-key or dial the feature code (Feature 96). In addition, you can dial the message waiting code from your idle telephone and send a message without ringing the telephone.

1. Dial an extension number. For example: Extension 11:



2. The extension must be ringing. If the extension answers in Hands-free mode, then you must press * to activate ringing. Press **msg** to send a message.



3. Press call me to send an immediate message to the extension. The called extension (ext 11) status bar will begin to flash.

Conditions

1. Feature *96 is used to disable the Message Waiting indication.
2. The **vm** option is only visible if the optional voice mail is installed.

MONITOR

Feature 7*

The Monitor feature is useful for purposes of quality assurance, and enables conversations to be monitored at other extensions. The extension which is monitoring a busy extension or CO line must have a higher priority setting for its Monitor Class of Service than the extension that is monitored.

Since this feature is very similar to Intrusion, it is possible to switch between these two features when Monitor has been invoked. The monitoring extension may press the **Mute** key to join in on an existing **Monitored** telephone call.

LEGAL NOTICE: This feature may violate privacy laws if used in a manner that is inconsistent with requirements of these laws. Iwatsu Voice Networks assumes no responsibility with regard to the use of this feature.

Conditions

1. The highest Class of Service is **0** the lowest CoS is **9**. At default, all extensions have a Monitor Class of Service of **5**.
2. Extensions with the same monitor Class of Service, may not monitor each other.
3. Monitor is only allowed if the called extension's Monitor Class of Service is lower than the calling extension's Monitor Class of Service.

MUTE

Feature 76

The Mute feature, which appears on a fixed key, allows the user to temporarily disable their microphone, which allows them to have a private conversation with someone in their office. Additionally, the mute key is used to enable two-way communication when the **Off-Hook Voice Announce** is used.

If the digital telephone is set to receive intercom calls using voice announce (Hands Free) and you are having a private conversation, simply press the mute key and the calling party can make an announcement, but will not be able to hear your conversation. You must press the mute key to talk to the calling party. When the call is terminated, the mute key must be pressed again.

Conditions

1. When **MUTE** is active, the display updates and the Auxiliary Lamp is lit solid.

OFF HOOK VOICE ANNOUNCE

Off-Hook Voice Announce (OHVA) allows the user to receive a voice announcement from another extension while they are using the handset on their telephone. The user's speakerphone is used to provide a second conversation path. An OHVA call can be rejected if the user chooses to not be interrupted from their current call.

1. To use Off Hook Voice Announce - Dial a busy extension. For example dial a busy extension (ext 11):



2. Press **next**:



3. Press **voic** (voice).
4. The display will update and you are now speaking through the busy extension's speaker:



5. The Called extension (in the example, ext 11) must have the receiver (handset) off hook, or you will get one double ring burst, and the display will update:



Conditions

1. The called extension must be off hook, on the handset, for OHVA to work. If a headset is being used and the handset is not off hook, OHVA will not work.
2. If the extension user has the Mute function activated, the line remains muted until the Off-Hook Voice Announce is complete.

ON HOOK DIALING (HOT KEY PAD)

Feature #6

On Hook Dialing allows the user to monitor the dialing of an outgoing call through the built-in speaker. The user may place an outgoing call without lifting the handset, allowing for hands-free operation. Simply lift the handset receiver to speak privately. If you wish to return to hands-free operation, press the speaker key and replace the handset.

Conditions

1. It is not recommended to disable the Hot Key Pad when Auto Line Select (Prime Line Pickup) (Feature 95) is set to a CO line or Line Group because it makes internal calling problematic.

ONE TOUCH TRANSFER

Extensions with a flexible key programmed as an extension can transfer a call by pressing the key and hanging up.

Conditions

1. An extension user may customize their telephone using **Feature #3**.

PAGE

Feature 50

Extension users may initiate various one-way page announcements:

- **All Paging** - All paging zones internal and external.
- **External Paging** - Only external ancillary paging equipment.
- **Internal Paging** - Specific page groups.
- **Internal Paging** - A system-wide internal page.

Conditions

1. Only one station may page at a time. If a second page is attempted, **PAGE BUSY** is displayed.
2. Single Line Telephones may initiate a page and use the Meet Me Page feature but will not receive a page announcement.

PAGE (ALLOW / DENY)

Feature #9

The Page Allow/Deny feature allows a user to enter a code to toggle between allowing or denying pages at their extension. Background Music programmed to play from this extension is not affected. When in the Page Deny mode, the telephone is still capable of initiating a page and use the **Meet Me** page feature. However, it is not able to receive a page.

Related Features

1. Meet Me Page (Feature 59).
2. Paging Allow (Feature #9).

Conditions

1. The Page Allow/Deny feature code can be stored on a feature key.
2. This feature does not affect Intercom Calls or Voice Announce Private.

PAGE (MEET ME)

Feature 59

Meet Me page allows the user to locate a person that is away from their desk or have no office location. Once paged, the party can answer the page, using any telephone in the system by entering the **Meet Me** (Feature 59) code. Once the code is entered, the system creates a private intercom call and releases the page port.

Conditions

1. A page may be answered at any telephone by dialing the Meet Me Page code even if the page announcement is not heard over the telephone speaker.
2. The page may be a zone page or a system wide **all page**.
3. The Meet Me Page code can be programmed on any available flexible key.

PAUSE / PAUSE INSERTION

Feature 70

The Pause/Pause Insertion feature places a deliberate delay in dialing when placing an outgoing CO line call from a stored number. Pause is useful in allowing access to special services where a delay is required. When entering a pause it appears as a **P** on the telephone display. A pause may be inserted in a number stored as an extension Speed Dial number or in a System (Common) Speed Dial bin.

Conditions

1. A pause occupies one digit position when stored in speed dial.

PHONE LOCK / UNLOCK

Feature 97

The Phone Lock/Unlock feature allows a user to prevent **ANY** outgoing CO line calls from their extension. The extension password is used to lock/unlock the telephone. This feature code is also used to program your private four-digit extension password.

WARNING! The use of the feature (Phone Lock) will block all CO line calls including 911. Therefore, it is not recommended that any telephone be locked.

Conditions

1. When an extension is locked it can only make intercom calls. Answering and receiving calls on hold are not affected.
2. If a user forgets their password it can be retrieved via system database administration.
3. The programmed Attendant's Private Password is used to enter Attendant Administration.
4. If a CO line or CO line call is attempted from a locked telephone, an error tone is heard and the display will read **PHONE LOCKED**.
5. The Phone Lock feature code can be programmed on a Flexible Feature key.
6. 911 calls cannot be dialed from a locked extension.

PROGRAMMABLE FEATURE KEY PROGRAMMING

Feature #3

Each digital telephone has dual-color Programmable Feature keys that can be programmed as a CO line, extension, or feature. These are called programmable features since each telephone is individually programmed and the programming can be changed at any time.

Programmable Feature Keys offer convenient, one-touch access to activate desirable features. Some programmed feature keys will light when activated (Call Forward, DND, DSS/BLF, etc.), while others do not (Background Music, Call Pick-Up, Last Number Redial, etc.).

Use the following steps to program or reprogram a Programmable Feature key:

1. While idle, press the **Feature** key.
2. Dial **#3**.
3. Press the key to be programmed.



4. The feature currently programmed under the key will be displayed. For example, if the voice mail key were pressed the following is displayed.



5. To identify the feature code displayed, press **show** within 3 seconds of pressing the flexible feature key. If the display returns to normal, simply press Feature #3 and the desired programmable feature key again.



6. To reprogram the feature key, press **chg** within 3 seconds of pressing the programmable feature key.



7. Select **line**, **ext** or **feat**.
- **line** - 1 - 9 (depending on the configuration)
 - **ext** - Any valid extension in the system
 - **feat** - Any valid feature.

8. **Example 1** - When programming an additional CO line (outside line):



- Enter the CO line to add or press **save** to clear this key:



9. **Example 2** - When programming an extension:



- Enter the extension that will appear on that programmable feature key or press **save** to clear this key:



10. **Example 3** - Programming a feature on a programmable feature key:



- Enter the feature code as seen in the feature code table at the beginning of this chapter or press **save** to clear this key:



- When entering in a new feature be sure to press the **Feature** key first - the **F** must be the first key pressed or the feature will not operate correctly. Example: Press the Feature key and dial 64 for feature 64 to operate correctly.
- lift the handset to exit programming.

Conditions

1. If an invalid code is dialed a single tone burst (error tone) will be heard and the display will read **CODE UNAVAILABLE**.
2. Valid feature codes must be in the form of either **Fn** or **Fnn** where **F** is the feature key and n is either a single-digit or two-digit code, including asterisk * and pound # dialed from the dial pad.
3. Any feature key programmed with a code previously assigned to a different feature key will cause the previously programmed feature key to become unassigned.
4. Programmable Feature keys can be cleared of any feature code/directory number by pressing **save** before entering a code/number.

PULSE TO TONE (DTMF) CONVERSION

The Pulse to Touch Tone (DTMF) conversion feature enables the system to use Dial Pulse (rotary) outgoing CO lines and access special services which require DTMF tones. A limited number of applications may still only support Pulse dialing for outgoing calls. After reaching an outside party, the use of Touch Tone mode may be required.

Conditions

1. The dialing conversion can only be from pulse mode to tone DTMF mode, not from DTMF back to pulse mode.
2. The Pulse-to-Tone code can be programmed in any speed dial bin.
3. When making a call on a CO line with Pulse Rotary dialing, the digits following * are sent in DTMF tone mode.

RECALL

The Recall feature pertains to calls that are parked, on hold, or calls that have been transferred to another extension. Calls which go unanswered after a preset period of time are **recalled** to the extension which initiated the park, hold, or transfer. Recall reduces the possibility that a call will go unattended.

Related Features

1. Call Forward
2. Transfer
3. Hold
4. Park

Conditions

1. Recalling CO lines follows Call Forward destination settings.
2. Recalls are not directed to the programmed Alternate Attendant extension.
3. When a holding or transferred call begins to recall, the outside party will hear transfer ring-back tone.
4. During recall, the CO line returns to System Hold allowing any extension with normal CO line receive privileges to retrieve the recalling line.

REMINDER TONES

Reminder Tones are heard when accessing intercom dial tone from an extension that has Call Forward or Do Not Disturb enabled. The Reminder Tone (stutter dial tone) is a rapid, recurring break in the intercom dial tone which reminds the user of the current extension availability status. If Call Forward or Do Not Disturb is activated this reminder tone is heard when the extension user places an intercom call.

Related Features

5. Call Forward (Feature 2)
6. Do Not Disturb (Feature 4)

Conditions

7. Once a digit is dialed, the Reminder Tone is removed until the next time intercom dial tone is heard.

RINGING LEVEL / MUTED RINGING

Ringling Level

The Volume Up and Volume Down keys adjust the ringing volume to one of four volume levels.

Muted Ringing

Incoming CO lines and intercom calls ring at the lowest ring volume level when the extension is active. Muted ringing only occurs when the called extension is busy, and it does not have busy or busy no answer forward enabled.

Conditions

1. Call Waiting (Feature 99) must be enabled.
2. Ringing levels can be adjusted from the lowest level 1 to the highest level 4.
3. An audible tone is heard when the maximum and minimum volume levels have been reached.
4. As ringing levels are adjusted the current setting is displays on the LCD.

RINGING LINE PRIORITY

The Ringing Line Priority feature follows an established priority schedule when connecting incoming calls. This system wide parameter will automatically connect incoming calls based upon this priority when there are multiple incoming calls to an extension. The user may override priority answering by directly pressing the direct appearing CO line, CO line group, feature key or by dialing an intercom number before going off-hook. The user may simply lift the handset to have the system assign the highest priority call to that extension.

Ringing Line Priority is: (Highest to Lowest)

- Callback – Extension.
- Callback - CO Line Recalling.
- CO Line call.
- Transferred CO Line call.
- Incoming CO Line call.
- Incoming ICM call.

Conditions

This is not a programmable parameter.

RELAY CONTROL

Feature 61(x) (x = Relay 1 – 4)

There are four relays on the **Option Module** which can be programmed to close when the feature code (Feature 61) plus the relay number 1 - 4 is dialed. For example, this closure can be used to open electronic door latches.

Conditions

1. The OPT (Option) Module must be installed.
2. A Flexible key can be programmed to activate a specific relay. When the relay is activated, the LED on the key is lit solid.
3. If this feature code is dialed and the selected relay is not operational, one double tone burst (error tone) is heard.

SAVE DIALED NUMBER (SDN)

Feature 51

Save Dialed Number (SDN) is used to retain a telephone number that was just dialed to be used later. Once stored, the number can be recalled by dialing the SDN feature code, regardless of what feature operations or numbers have been dialed at that extension since the number was saved. Only one number can be stored at a time.

Conditions

1. Saved Dial Number can store a maximum of 16 digits.
2. If all CO lines are busy when the redial is attempted the display will read **ALL CO LINES BUSY**.
3. The Save Dialed Number feature code can be stored on any Flexible Feature key for one-touch storing and dialing operation.

SPEAKERPHONE

The Speakerphone allows users to place and receive calls hands-free.

Conditions

1. The speakerphone function is impacted by environmental conditions.
2. Operation of the speakerphone in high noise areas may yield less than adequate results. If this is the case in the area where your telephone is located, the handset may be used to improve connection conditions.
3. To dial intercom numbers directly from an idle condition, the Hot Key setting must be enabled. Otherwise, the extension user must press a programmed Intercom key or press the ON/OFF button prior to dialing the extension number.

SECURITY CONTROL

Feature 62(x) (X = Sensor 1 – 4)

There are four sensors on the **Option Module** which can be programmed to set off an alarm indication. Once tripped, the alarm can be programmed to alert internal extensions with a special ring as well as call an external location. To deactivate the Security Alarm Sensor dial Feature 62 and enter the password.

1. Enter Feature 62.



2. Select all, or 1st to activate all or just the first Security Alarm Sensor, press next to select the 2nd, 3rd, and 4th sensor.



3. Enter the password that is used to activate and deactivate the Security Alarm Sensor.



4. The phone will return to idle

Conditions

1. The Option Module must be installed.
2. A Flexible key can be programmed to activate a specific relay. When the relay is activated the LED on the key is lit solid.
3. Each Relay can be programmed as a Relay or a Sensor, but not both.

SPEED DIAL (ABBR) – EXTENSION /SYSTEM

Feature 1

The Speed Dial feature allows users to store frequently dialed numbers. Each extension may store up to 20 personal numbers (bins 00 - 19) in the speed dial directory. Digital telephones enter and store their speed dial numbers using **Feature 1** to dial a stored number, press a CO line and enter Feature 1, followed by the bin number 00 - 19. The system may store 80 numbers (bins 20 - 99) for system-wide access. System Speed Dial numbers can be programmed by the Attendant (**Feature #0**) or customer database programming.

Each Speed Dial bin can store up to 16 digits, if more are required, speed dial bins can be chained together using **Feature 1**, plus the next speed dial bin to be used. Refer to Example 3 for speed dial entry examples.

Speed Dial One Touch: A short cut has been added to allow users to dial speed bins 00 - 11 quickly and easily. The user presses the feature key followed by one of the 12 flexible keys (not line keys) which are preprogrammed with station speed bins 00 - 19.

Programming System Speed Dial

Extension Speed bins are programmed and exclusive to each extension system speed bins are for system wide use. To program an extension personal speed bin:

1. Enter **Feature 1**, and the speed dial bin to be programmed. Valid entries are 00-19.



2. Press **show** then press **chg**.



3. Enter the number, up to 16 digits. If more are needed enter **Feature 1 and enter another speed bin**. This chains the two speed bins together allowing you to dial one speed bin location and have both speed bins dialed. Press **save**.

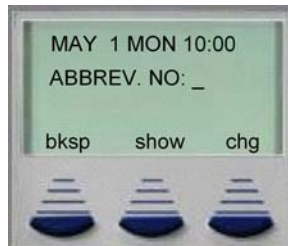

4. Enter the next speed bin to be programmed or press the **speaker** to exit.

Examples:

1. **Example 1** - To enter a CO line flash (hook-flash) in a System Speed number press Feature 3. The stored hook-flash is indicated by a / character for telephones with displays. For example, to enter **FLASH1389** in a system speed number the entry is: **Feature 3 + 1389**. The displayed system speed number is **/1389**.
2. **Example 2** - To enter a Pause in System Speed Dial, press **Feature 70**. A stored pause is indicated by a **P** character. For example, to enter **9P01188635773141** into a system speed number the entry is **9 + Feature 70 + 001188635773141**. The displayed system speed number is **9P01188635773141**.

3. **Example 3** - To chain one speed dial number to another, press **Feature 1** plus the speed dial number location to dial. For example, if a very long telephone number will not fit into one speed number location, split the number into two locations. To store the number **12345678901234567890** into locations 20 and 21:
- Enter into **location 20: 1234567890Feature 1 21**.
 - Enter into **location 21: 1234567890**.
 - Dial this sequence of numbers by accessing only one Speed bin location (location 20).

Special Entry Codes:

Display	Entry Code	Description
#	#	The Pound Key
@	Feature 1	Chaining Speed Bins Together
/	Feature 3	Flash Command to insert a flash in the dialing string
P	Feature 70	Insert a pause when dialing preprogrammed numbers

Conditions

1. A maximum of 16 digits can be entered into any one speed bin.
2. The system can be programmed to allow System Speed Dial Numbers to override Toll Restriction settings on both CO lines and extension Classes of Service.

STATUS MESSAGE

Feature 90

Digital Extension users can set a status message to alert intercom callers of the extension users' current status. The user can select between six pre-programmed messages, or customize one each time it is used. Pre-programmed messages include:

Pre-programmed Status Messages:

Number	Message	Number	Message
1	Out for lunch	5	Out of office
2	Be back soon	6	On vacation
3	Left for the day	7	Empty - customizable
4	In a meeting		

Conditions

1. The Status message will work even if the extension is in DND.
2. The called extension must be ringing to see the status message. If answered in hands-free mode, the status message does not display.
3. When customizing number 7. Use the standard keypad entry process.

Key Pad Entry Procedure

Digit	Press Once	Press Twice	Press Three Times	Press Four Times
1	Special Characters (See Enhanced Lettering Scheme)			
2	A	B	C	
3	D	E	F	
4	G	H	I	
5	J	K	L	
6	M	N	O	
7	P	Q	R	S
8	T	U	V	
9	W	X	Y	Z
*	Enters a number if pressed before the digit or lower case if pressed after the digit			
#	Space or go to the next character			

TEXT MESSAGES

The interactive LCD gives the user several options when calling a busy or unattended extension. For example, the user can press **cbck** to leave a generic call back message or press **msg** and select **preprog** and leave a pre-programmed text message. There are six pre-programmed messages.

Pre-programmed Messages

	Pre-programmed Messages
1	Have a good day
2	Call operator
3	Call home
4	Call back
5	Friend visiting
6	Urgent
7	Empty - customizable

Conditions

1. The called extension must be ringing to see the status message. If answered in hands-free mode, the message status does not display.
2. When customizing number 7. Use the standard keypad entry process.

Key Pad Entry Procedure

Digit	Press Once	Press Twice	Press Three Times	Press Four Times
1	Special Characters (See Enhanced Lettering Scheme)			
2	A	B	C	
3	D	E	F	
4	G	H	I	
5	J	K	L	
6	M	N	O	
7	P	Q	R	S
8	T	U	V	
9	W	X	Y	Z
*	Enters a number if pressed before the digit or lower case if pressed after the digit			
#	Space or go to the next character			

TOUCH TONE ON/OFF

Feature #1

Touch Tone On/Off can be used to customize a users' telephone tactile response of dial pad key operation. When On, pressing the dial pad keys causes a subtle beep tone to be emitted from the telephone speaker as an assurance that the key operation was successful. The factory **default** = Touch Tone **Off**.

Conditions

N/A

TRANSFER

Transfer is used to deliver calls from one extension to another extension while maintaining the privacy of the connection. This means that calls can be routed to system destinations (Extensions, Hunt Group, Voicemail Group, etc.) in such a way that the wrong party cannot easily intercept them.

There are two types of transfers you can use: Screened (talk) Transfer and Unscreened Transfer.

- **Screened Transfer** – means that before the transfer is completed, the call is announced to the destination extension. This transfer method provides the transferring party with the option to reroute the call being transferred if the selected destination is determined not appropriate.
- **Unscreened Transfer** – simply delivers the call to the destination selected regardless of the destinations readiness to accept the call.

Until the transfer is complete, the outside line is placed on Exclusive Hold and can only be retrieved by the transferring telephone or the receiving telephone.

Calls that are transferred are subject to a unique transfer recall time. Transferred calls that go unanswered at the destination will recall (ring) to the transferring party when this timer expires. There are two recall timers that affect transferred calls; Transfer Busy Recall Time and Transfer Idle Recall Time. Idle and Busy represent the status of an extension for unsupervised transfer scenarios. (If the extension destination is busy the Transfer-Busy Timer is used. If the extension destination is idle the Transfer-Idle Timer is used.)

Related Features

1. Recall.
2. Transfer Beep Enable (Feature 79).
3. Call Forward (Feature 2).
4. Forced Intercom Tone Ring (Feature 98).
5. Tone Ringing (Feature *).

Conditions

1. Transferred CO lines that recall are placed on system hold at the time the recall occurs.
2. When a transferring CO line recalls, the line number and extension number where the call was transferred from is displayed.
3. The transferred connecting party will hear a ring-back tone while the call is transferring.
4. CO line calls and intercom calls can be transferred.
5. During Screened Transfer, if the destination extension answers the intercom call in Voice Announce Hands-free mode and does not go off hook, the transferred connection will transfer ring at that extension.
6. During Screened Transfers if the destination extension answers the intercom call by lifting the handset, the transferred connection is connected to the destination extension immediately when the transfer operation is complete.

TRANSFER BEEP

Feature 79

When a call is transferred an audible tone is heard. Dial Feature 79 to disable this tone.

Conditions

N/A

VOICE ANNOUNCE / HANDS-FREE REPLY

Feature 98

The telephone provides the ability to receive incoming intercom calls with voice announce enabled, or disabled. When voice announce is enabled both parties are able to speak without pressing additional keys. However, if set to voice announce deny, the receiving extension receives a ring-back tone and must lift the handset or press the speaker key to answer the call.

For private conversations, press the mute key on your telephone and the voice announce option becomes private. You must press the mute key to speak to the calling party. The mute key must be reactivated each time.

The user can select between these modes as their needs change:

- **Voice Announce** – Hands Free Mode: Hands-free, gives the station user the ability to receive incoming intercom calls, without having to press any keys. The user receives a tone burst; the user and the intercom caller are instantly connected and can converse freely.
- **Tone Ring Mode** – All calls to this extension will ring. The user must press either the Speaker key or the lift the handset.
- **Voice Announce Private** – Once the Mute key is activated the next call will be considered private so the calling party cannot hear the private conversation. The Mute key must be reactivated after each call

Conditions

1. Extensions programmed for Hands-free (Voice Call Allowed) are automatically answered so calls will not automatically forward.
2. Extensions in ring or page mode with voice call allowed, can still receive voice calls if the calling extension presses the * key while the extension is ringing.
3. Extensions in ring or page mode with voice announce denied **cannot** receive voice announce calls.
4. During Tone Ringing, the LED associated to the speaker key will flash.
5. If a Flexible Feature key is programmed with the Intercom Mode Selection Code (**Feature 98**) the LED associated to that key indicates the current mode selection as follows:

Voice Call – Hands Free	LED will light steady
Tone Ringing Mode	LED will flash

VOICE CALL RECORDER (ONE TOUCH RECORD)

Feature 67

The Voice Call Recorder (One Touch Record) function is directly related to the OM-VML Voice Mail Card. If enabled in the database, this feature allows users to record external (CO line) conversations. When the Voice Recorder is activated, a connection is established between the extension and the voice mail system. The conversation is recorded in the extension's voice mailbox and stored in the Clipboard area.

Note: *Requires the OM-VML Card.*

Conditions

1. The feature can be assigned to a Programmable Feature key.
2. If a Programmable Feature key is used for this feature: During recorder setup, the associated LED for that key is lit solid. When the recording begins the lamp will change color but it will remain lit solid.
3. Extensions programmed into the Automatic Record Group, will not begin recording until the Call Duration Timer has expired.
4. Placing a call on hold constitutes completing a call and ends the recording function. Therefore, the feature code saving the recording must be dialed before placing the call on hold.

IMPORTANT NOTICE REGARDING THE CALL RECORDING FEATURE:

In certain states it is illegal to intercept and/or record telephone calls.

In certain states and under certain circumstances it is illegal to intercept for the purposes of listening in and/or recording telephone calls. Because such activity is not illegal in all jurisdictions and may be permitted in training and/or monitoring of personnel, this telephone system can be programmed to permit interception and/or recording with or without warning to those on the line. Before utilizing the system for such purposes, you are advised to consult with an attorney familiar with laws of the jurisdiction in which you utilize such feature.

IWATSU VOICE NETWORKS, its distributors, and the manufacturers responsible for this feature make no representations with respect to the legality of its use and disclaim any liability for claims and/or damages arising from the use or misuse of this feature.

VOLUME CONTROL

The digital speakerphone is equipped with a volume control that is used to adjust the various volume settings of the telephone. The following functions can be adjusted:

- Background Music.
- Paging.
- Headset Mode.
- Speakerphone.
- Handset.
- Ringer Volume.

Adjustment for each function is made while that function is in use. The digital telephone remembers the volume level selected for each function the next time that function is used. The Ringer volume adjustments allow for four volume levels.

Whenever one of the various modes is active, press the Volume Up or Down keys as necessary. The volume for this mode/function is now set.

Conditions

1. Users may adjust the ringing volume while the digital telephone is not in use or while it is ringing.
2. When adjusting the ring volume, the display will temporarily show the current setting.
3. When attempting to adjust the ringing volume beyond the highest or lowest setting, a single ring burst is heard to indicate that further adjustment is not possible.
4. Volume settings do not affect the transmit volume, only the receive volume.
5. A conversation with an outside party will not detect volume increases or decreases.

WARNING TONE / CO LINE CALL LIMITER

Each extension can be programmed with a warning tone, and CO line call limiter. Each inbound or outbound call is monitored for the length of the call, once the warning time timer is reached, the caller will receive the warning tone every 20 seconds for the duration of the call. In addition, the extension can be programmed to terminate the call after the first warning tone is heard. This feature is useful in a lobby or retail environment where lengthy calls are discouraged.

Conditions

1. This feature is not recommended as a Toll Saver option and should be used only for specific applications.
2. Additional calls can be made at the extension following the expiration of the Warning Tone/Drop Call operation.

Voice Mail System (OM-VML Card)

The optional OM-VML Voice Mail Card is designed to assist you in your daily tasks. Your voice mailbox becomes your primary assistant which can call you when you have a new message, as well as emailing you a copy of each message.

USING YOUR MAILBOX

If the OM-VML Voice Mail Card is installed in your telephone system, the display on your OM-KTD30 telephone will indicate how many **New** messages, and how many **Saved** messages are currently in your mailbox.

In the display you will see **N:00** which means that you have no new messages; if you had one new message the display will read **N:01**. Saved messages are indicated by reading **S:00**, which means that you have no saved messages. The following screen is an idle telephone display:



Set up

The following steps are used to set up your mailbox:

1. Press the **Voice Mail key** or Dial the **voice mail hunt group 87**.
2. Enter your **password** - Default password is **0000**.
3. **Press 3** to **change** your **password** from the default **0000**.
4. **Press 4** to **record** a personal **greeting**.
5. **Press 5** to **record** the **name** that is associated with this mailbox.

Your mailbox will give you the following list of options:

- 1** - Listen to New Messages
- 2_{ABC}** - Send a New Message
- 3_{DEF}** - Change Password
- 4_{GHI}** - Record Greetings
- 5_{JKL}** - Record Name
- 6_{MNO}** - Set Pager Notification
- 7_{PQRS}** - Cell Notification
- 8_{TUV}** - Assistant Extension
- 9_{WXYZ}** - Direct Message Delivery
- 0_{OPER}** - Reroute Callers to Another Extension
- *_{PHONE}** - Clipboard Recording
- #** - Exit

1 - Listen to new messages

- **Press 1 to listen** to any new messages in your mailbox.

2 - Send a new message

- **Press 2 to send** a message to another subscriber in the voice processing system.

3 - Change password

- **Press 3** to change your **password**. At default the password is 0000, and should be changed to something that you will remember, but is not easy for others to figure out. Try to avoid numbers like 1234 or 1111 because they are easy to figure out.

4 - Record Greetings

- **Press 4** to **customize** your mailbox. You should record a personal greeting that is informative to the caller. For example, “Hi, you’ve reached Ken, today Monday May first, I am out of the office but will be checking my messages so please leave me a message. Thank you.”

5 - Record Name and Setup Dial by Name

- **Press 5 to record your name.** This is used whenever a caller is transferred to your mailbox from the auto attendant. The name should only include your first and sometimes your last name. For example, you may say “Ken” or “Ken Williams”. For Dial by Name, the user can input the DTMF digits that represent the first three letters of their first and last names.

6 - Set Pager Notification

- **Press 6 to activate and enter a pager telephone number.** Once activated, the pager is notified each time a new message is received. Enter the pager telephone number, any delay needed after the telephone number is dialed, any numbers needed before sending the pager information, and finally enter the pager information that will be sent.

7 – Remote Notification (Cell Phone)

- **Press 7 to activate and enter the remote telephone number to be dialed** when a new message is left in your mailbox. Your voice mailbox will dial this number and begin to play the message that indicates that you have a new voice mail message. You will be prompted to enter your password to retrieve the message. This message begins to play as soon as it dials your remote telephone number, so when you answer your telephone it may not be at the beginning of the message. Just input your password and you will be able to retrieve your messages.

8 - Assistant Extension

- **Press 8 to set up an assistant extension.** A caller will have the option to be transferred to the assistant extension rather than leaving a message in your mailbox.

9 - Direct Message Delivery

- **Press 9 to activate direct message delivery** which will send callers that are in the auto attendant directly to your mailbox, without ringing your extension first.

0 - Reroute Caller to Another Extension

- **Press 0 and input a new extension number** where callers should be routed to when they enter your mailbox number. This can be very helpful when another extension is covering for you while you are on an extended absence.

*** - Clipboard Recording (One Touch Record)**

- All messages that are recorded while on a telephone call are placed into the clipboard area. These messages do not send any type of message notification to the extension, pager or remote telephone numbers.

- Exit

- Exit voice mail.

LISTENING TO MESSAGES

When you have a new message, your mailbox will notify you at your extension, in the display and with a visual flashing LED indication.

Enter your mailbox and press **1** to get your new message(s).

- 1** - Listen
- 2**_{MIC} - Save
- 3**_{DEF} - Delete
- 4**_{GR} - Reply
- 5**_{HL} - Header Information
- 6**_{MVO} - Copy Message
- *TONE** - Skip
- #** - Previous Menu

After listening to a new message, you will be presented with the following options:

1 - Listen

- **Press 1** to listen to new messages

2 - Save

- **Press 2** after listening to a new message if you would like to save the message. Messages are saved for up to 30 days. Messages that are stored for longer than 30 days will be deleted.

3 - Delete

- **Press 3** to delete the message that you have just listened to. You must **press 1** to confirm deletion of the message.

4 - Reply

- **Press 4** to reply to the message. Reply is only available when a subscriber sends you a message from their mailbox.

5 – Hear the Header Information

- **Press 5** to listen to the header or envelope information such as the time and date that the message was received.

6 - Copy the Message to Another Mailbox

- **Press 6** to copy or forward the message to another subscriber. The message can be copied with or without comments, and to multiple subscribers. To copy to multiple subscribers, enter the first mailbox number then press # enter the next mailbox number and press #. Continue until all mailboxes are entered. Press ## when you are done copying the message.

*** - Skip this Message and Save it as New**

- **Press *** to skip over this message and save it as a new message.

- Exit and Return to Previous Menu

- **Press #** to skip over this message return to the previous menu.

VOICE MAIL ACCESS FROM AN OUTSIDE LINE

Live Attendant

- Call into your office and an attendant answers the phone, have them:
- Press the Transfer key and dial 7* and then press the Transfer key again.
- When you hear the main greeting, press * and then enter your extension number.

Automated Attendant

- Call into your office and the Automated Attendant picks-up, press * and enter your extension number.

**Section 3 –
Attendant Position
User Guide**

OMEGA-PHONE 924

ATTENDANT POSITION

Any OM-KTD30 Digital Key Telephone may serve as the Attendant (At default the Attendant is extension 10). The Attendant supports several general system functions like Line Recall, Forced Incoming ICM Call Forward, and Manual Night or Alternate Service Mode Operation as well as Voice Mail Shutdown. The attendant receives all intercom calls directed to the Attendant Directory Number (default = 0).

A second (alternate) attendant position may be selected for common sharing of incoming CO line calls or load sharing during peak traffic periods.

The attendant's extension password allows for control of the system service mode (Day/ Evening/Alternate/Time), System (Abbr) Speed Dial number programming, Call Forward Status Lamp, Incoming Filter U, Incoming Filter R, Sensor Function and voice mail shutdown. The attendant extension may be connected to any digital extension port.

ATTENDANT ADMINISTRATION (ADMIN.)

Feature #0

Attendant Administration (Admin.) is used to set or modify the features:

- Service Mode (Day/Alt/Eve/Time).
- System (Abbr) Speed Dial Number programming.
- Call Forward Status Lamp.
- Incoming Filter U – Unrestricted.
- Incoming Filter R – Restricted.
- Sensor Function (Optional).
- Shutdown Voice Mail (Optional).

To enter Attendant Administration Programming:

1. Press **Feature #0**.
2. Enter the Administrator Password (Default = 9999).
3. Press **show**.
4. Press **next** to navigate through the Attendant Administration features

Attendant Administration can be performed from any OM-KTD30 or OM-8WRLS telephone. The Attendant Administration password is the same as the Extension Password of the assigned Attendant Extension. For example, if extension 10 is the attendant, then extension 10's password is used to enter attendant administration programming area.

CALL FORWARD STATUS LAMP CONTROL

All digital extensions have an auxiliary lamp or status bar above the LCD display. One feature of the status bar is to indicate when an extension is forwarded to another destination such as voice mail. The attendant can enable or disable the Call forward status for the Auxillary lamp.

INCOMING FILTER

The system provides a means to block the ringing of up to 50 different numbers based on the Caller ID information received. When a number is entered into the Incoming Filter table it is associated to a Service Mode (Always, Never, Day, Night, or Noon) so ringing for this call is cancelled during the desired time.

A second table (also with a maximum of 50 entries) is available to single-out desired telephone numbers from a larger group of numbers that are not desired. For example, all numbers from area code **976** are rejected, but there is one number from that group (976 - 555-1212) that you want to allow. This number is entered in the Ring table.

Programming Parameters:

Incoming Filter No Ring (MBC - 4-32-1)

- No Ring Mode (MBC - 4-32-1-1)
- Filter Phone No (MBC - 4-32-1-2)
- Filter Index Number (MBC - 4-32-1-3)

Incoming Filter Ring (MBC - 4-32-2)

- Ring Mode (MBC - 4-32-2-1)
- Filter Phone No (MBC - 4-32-2-2)
- Filter Index Number (MBC - 4-32-2-3)

Data Range

Incoming Filter U (No Ring).

- Mode: **Never**/Always/Day/Noon/Night.
- Filter Phone No—Filter Index 01-50: Empty.

Incoming Filter R (Ring).

- Mode: **Never**/Always/Day/Noon/Night.
- Filter Phone No—Filter Index 01-50: Empty.

Conditions

1. The system checks the **Filter U** (No Ring table), if it is active, and if a match is found, then the action is taken, otherwise the system will check Ring table if a match is found it will take that action. If there is no match, no action is taken.

OPTIONAL SENSOR FUNCTION

The system can be equipped with up to four security sensor connections, which when programmed can show if a device is left open. This function requires the option module and ancillary equipment such as door sensors, etc. The Attendant can set and reset the following sensor programming:

1. **SC. AL. DELAY** - A sensor will activate every time the contact is opened. This means that the sensor alarm may activate several times which may not be desirable. Therefore, the alarm delay (measured in minutes) allows a preset time to pass before the alarm sensor activates.
2. **SC. AL. Cancel** - Like an alarm system, the telephone system can alert internal or external parties of an open sensor. The Security Alarm Cancel is a timer which allows the situation to be investigated before sending the alert notification. This timer is adjustable from **0** (immediate) to **120 seconds**. If the password is not entered within the timer's setting, the system will begin the alert procedure.
3. **SC. AL. Period** - This is the period of time that the internal extension is alerted for an open sensor. Any external numbers will continue until the notification is complete or the Call Out Timer is reached (The Call Out Timer is set in system administration programming).
4. **SC. PSWD (0000)** - The Sensor Control Password is used to reset an alarm sensor once it has been activated.

SERVICE MODE

The system has two modes, day and night, which can be adjusted manually by the attendant or automatically, when the system is set to **Timed** mode. Specific features such as ringing destination, call forwarding and extension dialing privileges will change based on the active Service Mode.

When in timed mode, the system will cycle through day and night modes automatically, as defined in the time switching parameter in the database. If the attendant places the system into either day or night mode manually, it will remain in that mode until it is placed into a new mode or placed back into timed mode.

In addition, the Attendant extension can program a key to cycle through day and night modes without log into the attendant administration area. **Feature 63** plus the Attendant Extension Password will switch from Day to Night or Night to Day. When programmed on a key, the password can be programmed to allow one touch operation.

SYSTEM SPEED DIAL PROGRAMMING

1. To enter a **CO line flash** (hook-flash) in a System Speed bin, press **Feature 3**. The stored **hook-flash** is indicated by a / character at telephones with displays. For example to enter **FLASH1389** in a system speed number, the entry is: **Feature 3 + 1389**. The displayed system speed number is **/1389**.
2. To enter a **Pause** in a System Speed Dial, press **Feature 70**. A stored pause is indicated by a **P** character. For example, to enter **9P01188635773141** into a system speed number the entry is **9 + Feature 70 + 001188635773141**. The displayed system speed number is **9P01188635773141**.
3. To **chain one speed dial number to another**, press **Feature 1** plus the speed dial number location. For example; if a very long telephone number will not fit into one speed number location, split the number into two locations. To store the number **12345678901234567890**, for example, into locations 20 and 21:
 - Enter into location 20: **1234567890 Feature 1 21**.
 - Enter into 21: **1234567890**.
 - Dial this sequence of numbers by accessing only Speed dial bin location **20**.
 - A maximum of 16 digits can be entered into any one speed dial bin.

VOICE MAIL SHUTDOWN PROCEDURE

The Attendant can shutdown the voice mail system. **This procedure must be performed prior to a telephone system power down.**

1. Press **Feature #0** (From any digital station) and enter the **Attendant Password** to login as the Attendant.
2. Press **show**.
3. Press **back** (once) or press **next** (6 times) until the voice mail shut down procedure screen is displayed.



4. Press **show**.

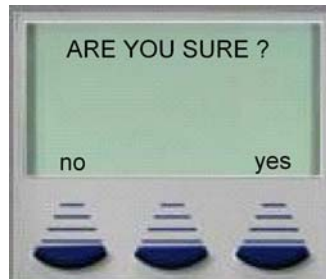

5. Press **yes** to shutdown the voice mail.

OMEGA-PHONE 924

**Section 4 –
Single Line Telephone
User Guide**

OMEGA-PHONE 924

SINGLE LINE TELEPHONES

This section lists the operations for the Omega-Phone 924 features which may be accessed by Single Line Telephones.

The feature operation codes listed in this guide are the preset codes that are automatically present when the Omega-Phone 924 is powered on.

Single Line Telephones (SLT)

Single Line or Analog telephones, like you use at home, have not changed significantly in many years. Generally, analog telephones are basic in design and have very few features. However, when attached to an Omega-Phone 924 system, you will find that an SLT has access to many of the same features as the OM-KTD30 Digital Key telephone, including Caller ID.

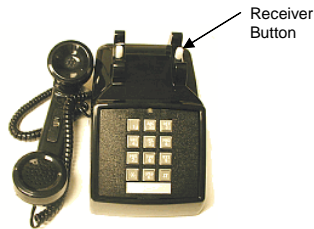

Single Line Telephone (SLT)

Note: *Caller ID information must be provided by the telephone company and will only appear on a SLT with a display.*

FEATURE CODES

Feature codes can be dialed at the time of operation. In several cases, the **Flash** key or Hook-Switch Flash must be pressed. This allows the system to give the SLT new dial tone, and access to additional features.

TELEPHONE FEATURE CODES

Feature (The # key is the Feature key on SLTs)	Single Line Telephones
Access Specific CO Line	# 0(x)
Account Code	4
Attendant	0
Authority Code (traveling CoS)	# 55
Call Back	#91
Call Forward	#2(y) Y = 0 - Idle Forward 1 - Busy Forward 2 - Direct Forward 3 - Follow Me 4 - No Answer 5 - Busy/No Answer
Call Pickup Directed	#54
Call Pickup Group	#53
Camp On (Busy Extension)	Ext + 2
Camp On (Busy CO Line)	#
CO Line Access	9
Directed Call Pick Up	# 53
Do Not Disturb (DND)	# 4
Extension Password - Phone Lock	#97
Extension Reminder	#92
Extension Reminder Delete	F*92
Flash (PBX/CO)	# 3
Group Call Pickup	# 54
Hold Retrieve (SLT) Same Extension	* 6
Hold Retrieve (SLT) Different Extension	* 7 EE EE=Extension
Hot Line	# #4
Last Number Redial	#8
Message Waiting	# 96 Send #*96 Cancel
Page	# 50(Z) Z= 0 - All Call 1 - External Page Only 2 - System All Call 3 + g - Group All Call g = 1 - 9
Page Answer (Meet Me)	# 59
Phone Lock	# 97
Pulse to Tone	*
Speed Dialing (SLT)	# 1 to store * 1 to Dial
Voice Mail	#64

FEATURE OPERATION

ACCESSING SPECIFIC CO LINES

#0(x)

To access an available line dial 9 or to access a specific line or Dial # followed by 0(x), where (x) = the Line 1 - 9. This allows both Single Line and Digital Key telephones the ability to access specific outside lines rather than dialing the line group code.

Conditions:

1. The CO line must be connected to the telephone company facility or error tone will be heard.

ACCOUNT CODE

4

Account Codes are passwords that are verified in the database, which are used for two different reasons. One reason is to grant different dialing privileges, when a valid Account Code is entered, for example, it may temporarily grant access to long distance dialing. The second reason is to create a record, with the use of Station Message Detail Recording (SMDR). Extensions may be forced to use account codes before dialing out on any telephone company line or it can be voluntary. All Account Codes are verified.

AUTHORITY CODE (TRAVELING CLASS OF SERVICE)

#55

Authority Codes are used to enable a higher Class of Service to an extension with a lower Class of Service. When using Authority Codes, the extension password must be entered.

1. Enter #55
2. Enter your extension number
3. Press Save
4. Enter your extension password
5. Press Save

Conditions:

1. Error tone is heard when an invalid Account Code is entered, and the telephone will return to an idle state.
2. When a valid account code is dialed the extension is connected to a CO line, and the Account Code's Class of Service is verified before a call is placed.

CALL ATTENDANT (OPERATOR)

0

The extension that is programmed as the Attendant may receive multiple internal calls via the Operator Code **0**.

Conditions:

1. The Operator Code (0) is in addition to the default assigned two-digit intercom number for the extension.
2. The attendant two-digit extension number can be assigned to any feature key.

CALL BACK – EXTENSION

#91

This feature allows the user to queue an extension which is busy, in Do Not Disturb (DND), or idle. When a user sends a Call Back to a busy extension, the Call Back process will begin when the busy extension hangs up. When Call Back is sent to an idle extension, the Call Back process will begin once the user performs an operation at that extension and then hangs up.

SLT Operation:

When the Call Back process begins the user will hear bursts of tone signaling them to pick up the handset. The queued extension begins ringing.

Conditions:

1. To invoke a Call Back at an extension that is in the Voice Announce mode, the user must press Force Tone Ringing (*).
2. The Call Back process begins when both the user's extension and the called party's extension are idle (on-hook).

CALL FORWARD

#2

There are several call forward options to choice from so that each extension user can customize their own call forwarding.

- Idle - Forward all calls.
- Busy - Forward calls only when the extension is busy.
- Follow Me - Use the follow me feature to receive calls at a temporary location and activate the feature remotely from another extension.
- No Answer - Forward calls that go unanswered at an extension.

Conditions:

Forward conditions may be set as follows for each call forward type:

- Intercom calls only.
 - Intercom and CO line (including transferred CO Lines) calls.
 - CO line calls only.
1. Press #2.
 2. Using the table on the following page: Enter the type of call forwarding, followed by the destination, what type of calls to forward, and the no answer time if applicable.

One Touch and Single Line Telephone Forward Operations. (The # key is the Feature key on SLTs)

Fwd Type	Feature Codes	Fwd Code	Destination	ICM or ICM/CO or CO	No Ans Time	Entry Code
Idle	#2	0	87 Voice Mail 10 - 37 Extension 82 - 89 Hunt Group	ICM=1 ICM/CO=2 CO=3		#20872
Busy	#2	1				#21872
Direct	#2	2				#22872
Follow Me	#2	3				#238722
No Answer	#2	4			1=10 2=20 3=30 4=40 5=50	#24872
Busy/No Answer	#2	5			1=10 2=20 3=30 4=40 5=50	#258722

Conditions:

1. Intercom calls to a forwarded extension receive a special tone signifying that the extension called is forwarded.

CALL PICK-UP GROUP

#53 / #54

An extension can answer calls ringing at another extension by using the Call Pick-Up Group feature. This feature allows users to easily access calls ringing within a group by dialing the pick-up code or pressing the preprogrammed key.

If multiple calls are ringing at an extension, a priority list determines which call will be answered first.

Call Pick-Up Priority List:

- Camped-On CO Line Calls.
- Recalling CO Line Calls.
- Transferred CO Line Calls.
- Incoming CO Line Calls.
- Tone Ringing Intercom Calls.

Conditions:

1. If the call at the dialed extension has stopped ringing before the call is picked-up, the user will hear error tone.
2. The Call Pick-Up feature code can be programmed on any programmable feature key.
3. If several calls (with the same priority) are ringing at an extension, the calls are answered in the order in which they are received.

DO NOT DISTURB

#4

Extension users have the ability to place their extension in Do Not Disturb. When invoked, Do Not Disturb (DND) prevents all calls, intercom, and CO line calls, from ringing at an extension in the Do Not Disturb state. Some extensions with a higher Class of Service (CoS) have the ability to override an extension's DND setting.

A short stutter tone is audible when DND is active. A digital telephone is capable of having the DND feature assigned to a programmable key that will light whenever DND is active. Other extensions with a programmed DSS/BLF key for that extension in Do Not Disturb will flash indicating that the extension is in DND.

Conditions:

1. Do Not Disturb cannot be enabled if Station Call Forward is active.
2. To redirect a ringing call to the attendant, press the preprogrammed DND feature key while the call is ringing.
3. When an extension is in DND, all other extensions with a DSS/BLF for that extension will flash, indicating that the extension is in DND.

EXTENSION PASSWORD

#97

Each extension has a User Password which is needed to access certain features such as; Follow Me Forward, Authority Code, and Phone Lock features.

Conditions:

1. Each extension can customize their password at any time.

EXTENSION PICK-UP GROUPS

#54

Extension pick-up groups allow you to dial a code and pick up an actively ringing call within your group.

Conditions:

1. Extensions may be assigned to only one Extension Pick-Up Group.
2. The pick-up priority of a ringing call is: CO lines and then intercom calls, CO line call priority is Camped-On, Recalling, Transferred, and Incoming.

EXTENSION REMINDER

Feature 92

Each extension has a private alarm that can be used to remind them of special appointments, events, etc. When the Extension Reminder activates, the user will hear ring tone for a programmable period of time ranging from 10 to 60 seconds. After the programmed period, the Extension Reminder is automatically canceled. The extension user can program the Extension Reminder to be activated once or always (repeated). When programmed for always, the Extension Reminder will sound at the same time everyday.

Conditions

1. The Extension Reminder is automatically canceled after the programmed reminder play time.
2. The Extension Reminder time is entered in military (24 hour) format. For example: 8:05pm is entered as 20:05.

FLASH – CENTRAL OFFICE (CO) LINE

Feature 3

Flash – Central Office Line is a programmed setting that will determine what flash timing will be presented to the telephone company central office when the user issues a Hook-Flash command while connected to a CO line. This feature is a requirement when the system is installed behind a Centrex or PBX system. For easy access it is recommended, in these two cases, the Flash feature code is programmed onto a Programmable Feature key.

If Call Waiting is provided, by the telephone company, the Flash feature is used to answer a second incoming call while connected to another outside party.

Conditions

1. The Flash code may be stored in any speed dial bin.
2. The Flash code may be stored in the Last Number Redial buffer.
3. SLT extensions must generate a hook-flash on the single line port the dial #3 to generate a hook-flash on a CO line.

FORCED INTERCOM TONE RING

When an extension is in Hands Free - Voice Announce mode, intercom calls will not forward, so the system allows callers to dial * to activate Forced Intercom Tone Ring which allows callers to ring the extension.

Conditions:

1. When an extension leaves a callback, the alert signal will ring.

GROUP CALL PICK-UP

#54

See Call Pick-up.

HOLD

A Single Line Telephone can place calls on hold by pressing a fixed **Flash** key or by pressing the hook-switch.

LAST NUMBER REDIAL

#8 or fixed redial key

Last Number Redial (LNR) allows the user to automatically dial the last number dialed from your telephone. The LNR feature retains up to 20 digits for each extension.

Conditions:

1. Last Number Redial only works with CO line calls.
2. LNR will repeat a hook-flash in the same sequence as it was first dialed. If a speed dial number was first dialed LNR will dial the speed dial number and any subsequent manually dialed digits.

LEAST COST ROUTING

#68

Least Cost Routing (LCR) allows the system to evaluate each telephone number dialed to ensure that the correct trunk route is used.

Conditions:

1. This feature must be enabled in database programming.

MESSAGE WAITING

#96

When you call a busy or unattended extension, you have the option to send a message waiting indication. You can also dial the message waiting code from your idle telephone and send a message without ringing the telephone.

Conditions:

1. **Feature #*96** is used to disable a Message Waiting Indication.

PAGE

#50

Extension users may initiate various one-way page announcements:

- **All Paging** - All paging zones internal and external.
- **External Paging** - Only external ancillary paging equipment.
- **Internal Paging** - Specific page groups.
- **Internal Paging** - A system-wide internal page.

Conditions:

1. Only one station may page at a time. Error tone is heard if a second page is attempted.
2. A Single Line Telephone may initiate a page and use the Meet Me Page feature will not receive a page announcement.

PAGE (MEET ME)

#59

Meet Me Page allows the user to locate a person that is away from their desk or has no office location. A party can answer a page using any telephone in the system by entering the **Meet Me (#59)** code. Once the code is entered, the system creates a private intercom call and releases the page port.

Conditions:

1. By dialing the Meet Me Page code, a page can be answered from any telephone, even if the page announcement is not heard over the telephone speaker.
2. The page can be a zone page or a system wide **all page**.

PHONE LOCK / UNLOCK

#97

The Phone Lock/Unlock feature allows a user to prevent **ANY** outgoing CO line calls from their extension. The extension password is used to lock/unlock the telephone. This feature code is also used to program your private four-digit extension password.

WARNING! The use of this feature (Phone Lock) will block all CO line calls, including emergency calls such as 911. Therefore, it is not recommended that any telephone be locked.

Conditions:

1. When an extension is locked, only intercom calls can be made from that extension; answering and retrieving calls on hold are not affected.
2. If a user forgets their password, it can be retrieved via the system database administration.
3. The programmed Attendant's Private Password is used to enter Attendant Administration.
4. Error tone is heard if CO line access or a CO line call is attempted from a locked telephone, error tone will be heard.
5. 911 calls cannot be dialed from a locked extension.

PULSE TO TONE (DTMF) CONVERSION

The Pulse to Touch Tone (DTMF) conversion feature enables the system to use Dial Pulse (rotary) outgoing telephone company lines and access special services which require DTMF tones. A limited number of applications may still only support Pulse dialing for outgoing calls, but after reaching an outside party, the use of Touch Tone mode may be required.

Conditions:

1. The dialing conversion can only be from pulse mode to tone DTMF mode, not from DTMF back to pulse mode.
2. The Pulse to Tone code can be programmed in any speed dial bin.
3. When making a call on a CO line with Pulse Rotary dialing, the digits following the asterisk (*) are sent in DTMF tone mode.

RECALL

The Recall feature pertains to calls that are parked, on hold, or calls that have been transferred to another extension. Calls which go unanswered after a preset period of time are **recalled** to the extension which initiated the park, hold, or transfer. Recall reduces the possibility that a call will go unattended.

Conditions:

1. Recalling telephone company lines will follow Call Forward destination settings.
2. Recalls are not directed to the programmed Alternate Attendant extension.
3. When a holding or transferred call begins to recall, the outside party will hear transfer ring-back tone.
4. During recall, the CO line will return to System Hold. This allows any extension with normal CO line receive privileges to retrieve the recalling line.

REMINDER TONES

Reminder Tones are heard when accessing intercom dial tone from an extension that has Call Forward or Do Not Disturb enabled. The Reminder Tone (stutter dial tone) is a rapid, recurring break in the intercom dial tone which reminds the user of the current extension availability status. If Call Forward or Do Not Disturb is activated, this reminder tone is heard when the extension user places an intercom call.

Conditions:

1. Once a digit is dialed, the reminder tone is removed until the next time intercom dial tone is heard.

SINGLE LINE TELEPHONE - FLASH

Single Line Telephones and similar analog devices use a Hook-switch Flash or Flash key to administer call-processing operations like transfer and hold. This fundamental call control is handled in the form of specific hook-switch operations. These are known as Hook-switch Flash or just Flash commands.

Conditions:

N/A

SPEED DIAL (ABBR) – EXTENSION /SYSTEM

#1

Single Line Telephones can store up to 20 station speed bins using the #1 feature code. To dial a speed bin, a Single Line Telephone uses the *1 feature code.

Special Entry Codes:

Display	Entry Code	Description
#	#	The Pound Key
@	Feature 1	Chaining Speed bins together
/	Feature 3	Flash command to insert a flash in the dialing string
P	Feature 70	Insert a pause when dialing the preprogrammed numbers

Conditions:

1. A maximum of 16 digits can be entered into any one speed bin.
2. The system can be programmed to allow System Speed Dial Numbers to override Toll Restriction settings on both CO line and Extension Classes of Service.

TRANSFER

Transfer is used to deliver calls from one extension to another extension while maintaining the privacy of the connection. This means that calls can be routed to system destinations (Extensions, Hunt Group, Voicemail Group, etc.) in such a way that the wrong party cannot easily intercept them.

There are two types of transfers you can use: Screened (talk) Transfer and Unscreened Transfer.

- **Screened Transfer** – means that before the transfer is completed, the call is announced to the destination extension. This transfer method provides the transferring party with the option to reroute the call being transferred if the selected destination is determined not appropriate.
- **Unscreened Transfer** – simply delivers the call to the destination selected, regardless of the destination's readiness to accept the call.

Until the transfer is complete, the outside line is placed on Exclusive Hold and can only be retrieved by the transferring telephone or the receiving telephone.

Calls that are transferred are subject to a unique transfer recall time. Transferred calls that go unanswered at the destination will recall (ring) the transferring party when this timer expires. There are two recall timers that affect transferred calls; Transfer Busy Recall Time and Transfer Idle Recall Time. Idle and Busy represent the status of an extension for unsupervised transfer scenarios. (If the extension destination is busy the Transfer-Busy Timer is used. If the extension destination is idle the Transfer-Idle Timer is used.)

Conditions:

1. Transferred CO lines that recall are placed on system hold at the time the recall occurs.
2. When a transferred CO line recalls, the line number and extension number where the call was transferred is displayed.
3. The transferred connecting party will hear ring-back tone while the call is transfer ringing.
4. CO line calls and intercom calls can be transferred.
5. In screened transfer, if the destination extension answers the intercom call in Voice Announce Hands-free mode and does not go off hook, the transferred connection will transfer ring at that extension.
6. In screened transfers, if the destination extension answers the intercom call by lifting the handset, the transferred connection is connected to the destination extension immediately when the transfer operation is complete.

WARNING TONE / CO LINE CALL LIMITER

Each extension can be programmed with a warning tone and CO line call limiter. Each inbound or outbound call is monitored for the length of the call, once the warning time timer is reached the caller will receive a warning tone every 20 seconds for the duration of the call. Also, an extension can be programmed to terminate a call after the first warning tone is heard. This feature is useful in a lobby or retail environment where lengthy calls are discouraged.

Conditions:

1. This feature is not recommended as a Toll Saver option and should be used only for specific applications.
2. Additional calls can be made at the extension following the expiration of the Warning Tone/Drop Call operation.

Voice Mail System (OM-VML Card)

The optional OM-VML Voice Mail Card is designed to assist you in your daily tasks. Your voice mailbox becomes your primary assistant which can call you when you have a new message, as well as emailing you a copy of each message.

USING YOUR MAILBOX

Set up

The following steps are used to set up your mailbox:

1. Dial the voice mail hunt group 87 or dial #64
2. Enter your password - Default password is 0000.
3. Press 3 to change your password from the default 0000.
4. Press 4 to record a personal greeting.
5. Press 5 to record the name that is associated with this mailbox.

Your mailbox will give you the following list of options:

- 1** - Listen to New Messages
- 2_{ABC}** - Send a New Message
- 3_{DEF}** - Change Password
- 4_{GHI}** - Record Greetings
- 5_{JKL}** - Record Name
- 6_{MNO}** - Set Pager Notification
- 7_{PQRS}** - Cell Notification
- 8_{TUV}** - Assistant Extension
- 9_{WXYZ}** - Direct Message Delivery
- 0_{OPER}** - Reroute Callers to Another Extension
- *_{TONE}** - Clipboard Recording
- #** - Exit

1 - Listen to new messages

- Press **1** to **listen** to any new messages in your mailbox.

2 - Send a new message

- Press **2** to **send** a message to another subscriber in the voice processing system.

3 - Change password

- **Press 3** to change your **password**. At default the password is 0000, and should be changed to something that you will remember, but is not easy for others to figure out. Try to avoid numbers like 1234 or 1111 because they are easy to figure out.

4 - Record Greetings

- **Press 4** to **customize** your mailbox. You should record a personal greeting that is informative to the caller. For example, "Hi, you've reached Ken, today is Monday May first and I am out of the office, I will be checking my messages so please leave me a message. Thank you."

5 - Record Name and Setup Dial by Name

- **Press 5** to **record your name**. This is used whenever a caller is transferred to your mailbox from the auto attendant. The name should only include your first and sometimes your last name. For example, you may say "Ken" or "Ken Williams". For Dial by Name, the user can input the DTMF digits that represent the first three letters of their first and last names.

6 - Set Pager Notification

- **Press 6** to activate and enter a **pager number**. Once activated, the pager is notified each time a new message is received. Enter the pager telephone number, any delay needed after the telephone number is dialed, any numbers needed before sending the pager information, and finally enter the pager information that will be sent.

7 - Remote Notification (Cell Phone)

- **Press 7** to activate and enter the remote telephone number to be dialed when a new message is left in your mailbox. Your voice mailbox will dial this number and begin to play the message that indicates that you have a new voice mail message. You will be prompted to enter your password to retrieve the message. This message begins to play as soon as it dials your remote telephone number, so when you answer your telephone it may not be at the beginning of the message. Just input your password and you will be able to retrieve your messages.

8 - Assistant Extension

- **Press 8** to set up an **assistant extension**. A caller will have the option to be transferred to the assistant extension rather than leaving a

message in your mailbox.

9 - Direct Message Delivery

- **Press 9** to activate direct message delivery which will send callers that are in the auto attendant directly to your mailbox, without ringing your extension first.

0 - Reroute Caller to Another Extension

- **Press 0** and input a new extension number where callers should be routed to when they enter your mailbox number. This can be very helpful when another extension is covering for you while you are on an extended absence.

*** - Clipboard Recording (One Touch Record)**

- All messages that are recorded while on a telephone call are placed into the clipboard area. These messages do not send any type of message notification to the extension, pager or remote telephone numbers.

- Exit

- Exit voice mail.

LISTENING TO MESSAGES

When you have a new message, your mailbox will notify you at your extension, in the display and with a visual flashing LED indication.

Enter your mailbox and press **1** to get your new message(s).

- 1** - Listen
- 2_{ABC}** - Save
- 3_{DEF}** - Delete
- 4_{GHI}** - Reply
- 5_{JKL}** - Header Information
- 6_{MNO}** - Copy Message
- *_{TONE}** - Skip
- #** - Previous Menu

After listening to a new message, you will be presented with the following options:

1 - Listen

- **Press 1** to listen to new messages

2 – Save

- **Press 2** after listening to a new message if you would like to save the message. Messages are saved for up to 30 days. Messages that are stored for longer than 30 days will be deleted.

3 - Delete

- **Press 3** to delete the message that you have just listened to. You must **press 1** to confirm deletion of the message.

4 - Reply

- **Press 4** to reply to the message. This only works when a subscriber sends you a message from their mailbox.

5 – Hear the Header Information

- **Press 5** to listen to the header or envelope information such as the time and date that the message was received.

6 - Copy the Message to Another Mailbox

- **Press 6** to copy or forward the message to another subscriber. The message can be copied with or without comments, and to multiple subscribers. To copy to multiple subscribers, enter the first mailbox number then press #, and then enter the next mailbox number and press #, continue until all mailboxes are entered. Press ## when you are done copying the message.

*** - Skip this Message and Save it as New**

- **Press *** to skip over this message and save it as a new message.

- Exit and Return to Previous Menu

- **Press #** to skip over this message return to the previous menu.

Section 5 – Doorphone User Guide

OMEGA-PHONE 924

DOORPHONES

The OM-DDPH Doorphone provides an economical and simple method to allow visitors to make an intercom call to gain entrance to your building.

Operation

To place a call from a Doorphone:

1. Press and release the key on the Doorphone, you will hear a ringing tone and the lamp on the key will change from red to green.
2. Wait for an answer.
3. Announce yourself.

To call a Doorphone:

1. Lift the receiver.
2. Dial the assigned extension number for the door phone.

Or

1. Press the DSS key assigned for the desired Doorphone.
2. Make an announcement.

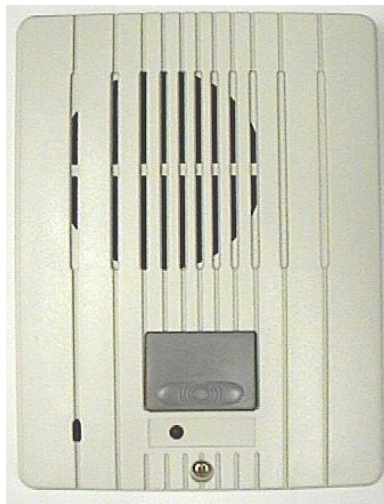

DOORPHONE (OM-DDPH)

NOTES: